

 **West Marine**<sup>®</sup>

# VHF680

***Class 'D' DSC Marine  
Radio with Hailer  
Radio maritime ASN de classe 'D'  
avec appel à la voix***



***Owner's Manual  
Guide d'utilisation***

*Model/modèle 12019147*

# MAKING A VOICE DISTRESS CALL

Lift the red cover. Press and hold the **DISTRESS** button for three seconds. Your radio transmits your boat's location every few minutes until you receive a response.

 **NOTE: If the radio displays *Enter User MMSI*, cancel the automatic distress call and make a normal voice distress call.**

## Making a Voice Distress Call

Speak slowly - clearly - calmly.

For future reference, write your boat's name & call sign here:

1. Make sure your radio is on.
2. On the radio, press the **16/9-TRI** button to switch to Channel 16 (156.8 MHz). (If the corner of the display does not show 16, press the **16/9-TRI** button again until it does.)
3. Press the **PUSH-TO-TALK** button on the microphone and say: "**MAYDAY -- MAYDAY -- MAYDAY.**"
4. Say "**THIS IS** {name of your boat (three times) and call sign/boat registration number (once)}."
5. Say "**MAYDAY** {name or call sign of your boat}."
6. Tell where you are: (what navigational aids or landmarks are near, or read the latitude and longitude from your GPS).
7. State the nature of your distress, e.g. are you sinking, medical emergency, man overboard, on fire, adrift, etc.
8. State the type of assistance you need (medical, towing, pumps, etc.).
9. Give number of persons aboard and conditions of any injured persons.
10. Estimate present seaworthiness of your ship (e.g. how immediate is the danger due to flooding or fire or proximity to shore).
11. Briefly describe your ship, giving the ship name (e.g. "Blue Duck is 32 foot cabin cruiser, white hull, blue deck house").
12. Say: "**I WILL BE LISTENING ON CHANNEL 16.**"
13. End message by saying "**THIS IS** {name or call sign of your boat}, **OVER.**"
14. Release the **PUSH-TO-TALK** button and listen.

**If you do not get an answer after 30 seconds, repeat your call, beginning at step 3, above.**

# FAIRE UN APPEL DE DÉTRESSE VOCAL

Soulevez le couvercle rouge. Maintenez la touche **DISTRESS** enfoncée pendant trois secondes. La radio transmet la position de votre bateau à intervalles réguliers de quelques minutes, jusqu'à ce que vous receviez une réponse.

 **REMARQUE : Si la radio affiche *Enter User MMSI (Entrer l'ISMM de l'utilisateur)*, annulez l'appel de détresse automatique et faites un appel de détresse couvercle rouge et vocal standard.**

## Faire un appel de détresse vocal

**Parlez lentement – clairement – calmement.**

Pour toute référence ultérieure, transcrivez ci-dessous le nom et l'indicatif d'appel de votre bateau :

1. Vérifiez si votre radio est en marche.
2. Appuyez sur la touche **16/9-TRI** de la radio afin de commuter au canal 16 (156,8 MHz). (Si le canal 16 n'apparaît pas à l'affichage, appuyez de nouveau sur la touche **16/9-TRI** jusqu'à ce qu'il soit affiché.)
3. Appuyez sur le bouton de microphone **PUSH-TO-TALK** et dites : "**MAYDAY - MAYDAY - MAYDAY**".
4. Donnez l'identité de votre navire en disant : "**ICI** {*nom de votre bateau (trois fois) ou indicatif d'appel et le numéro d'identification de votre bateau (une fois)*}".
5. Dites "**MAYDAY** {*nom ou indicatif d'appel de votre bateau*} une fois".
6. Donnez votre position : (quels sont les points de repère ou aides à la navigation près de vous ou lisez les coordonnées de longitude et de latitude apparaissant sur votre dispositif GPS).
7. Révélez la nature de votre détresse (par exemple, nous sommes en train de couler, urgence médicale, un homme à la mer, un incendie, nous sommes à la dérive, etc.
8. Révélez la nature de l'assistance désirée (médicale, remorquage, essence, etc.)
9. Donnez le nombre de personnes à bord et les conditions des blessés, s'il y en a.
10. Donnez la condition de navigabilité actuelle de votre navire, tel que le degré de l'urgence par rapport à l'inondation, à l'incendie ou à votre proximité de la côte.
11. Donnez une brève description de votre navire en donnant le nom du bateau (par exemple, "Blue Duck est un yacht de croisière de 32 pieds, avec une coque blanche et un rouffle bleu.").
12. Dites : "**JE VAIS ÉCOUTER SUR LE CANAL 16**".
13. Terminez le message en disant "**ICI** {*nom ou indicatif d'appel de votre bateau*}, **À VOUS**".
14. Relâchez le bouton **PUSH-TO-TALK** du microphone et écoutez.

**Si vous n'obtenez pas de réponse après 30 secondes, répétez l'appel en commençant à l'étape 3 ci-dessus.**

# CÓMO HACER UNA LLAMADA DE APURO

Levante la tapa roja. Mantenga oprimido el botón **DISTRESS** por tres segundos. La radio transmitirá la localidad de su nave cada cuantos minutos hasta que reciba una respuesta.



**Nota: Si la radio exhibe (Inserte el MMSI del usuario), cancele la llamada de apuro automática y haga una llamada de apuro normal por voz.**

## Cómo hacer una llamada de apuro por voz

Hable despacio -- claro -- y con calma.

Para acordarse en el futuro, escriba el nombre y la señal de su nave aquí:

1. Asegúrese de que la radio está encendida.
2. En la radio, oprima el botón **16/9-TRI** para cambiar al canal 16 (156.8 MHz). (Si la esquina de la pantalla no muestra 16, oprima el botón **16/9-TRI** otra vez hasta que lo haga.)
3. Oprima el botón **PUSH-TO-TALK** (Oprima para hablar) en el micrófono y diga: **“MAYDAY --- MAYDAY--- MAYDAY.”**
4. Diga **“ESTE ES {nombre de su nave (tres veces) y la señal/ número de registración de la nave (una vez)}.”**
5. Diga **“MAYDAY {nombre o señal de su nave}” una vez.**
6. Describa donde se encuentra: (ayudas de navegación o marcas destacadas cercanas, o lea la latitud y la longitud en su GPS).
7. Describa la clase de su apuro, ej., se está hundiendo, emergencia médica, hombre al agua, hay fuego, está a la deriva, etc.
8. Describa el tipo de asistencia que necesita (atención médica, remolque, bombas, etc.).
9. Describa la cantidad de personas abordo y las condiciones de cualquier persona lesionada.
10. Estime la navegabilidad actual de su nave, ej., cuanto de inmediato es el peligro de inundación o de incendio o proximidad a la costa.
11. Describa brevemente su nave (ej., “Blue Duck es un yate de 32 pies, casco blanco, cabina azul”).
12. Diga: **“ESTARÉ ESCUCHANDO EN EL CANAL 16.”**
13. Termine el mensaje diciendo: **“ESTE ES {nombre o señal de su nave}, OVER.”**
14. Suelte el botón **PUSH-TO-TALK** y escuche.

**Si no recibe una contestacion dentro de 30 segundos, repita su llamada, comenzando con el paso 3, descrito arriba.**

Visite [www.westmarine.com](http://www.westmarine.com) para bajar el manual en español de la radio VHF680.

# Contents

Making a Voice Distress Call .....	ii	Making DSC Calls .....	16
Faire un appel de détresse vocal .....	iii	Making an Automatic Distress Call.....	17
Cómo hacer una llamada de apuro por voz .....	iv	Receiving DSC Calls .....	17
<b>Introduction .....</b>	<b>1</b>	Test Calls .....	19
Radio Features .....	1	Position Request and Reply .....	19
<b>Getting Started .....</b>	<b>2</b>	Putting the Radio into Standby .....	21
What's Included .....	2	Disabling Automatic Channel Switching.....	21
Parts of the Radio .....	3	<b>Using the Hailer and FogHorn .....</b>	<b>21</b>
Turning on the Radio.....	5	Connecting the Hailer/Foghorn Speaker.....	21
Setting the UIC Channel Mode (USA/CAN/INT) .....	5	Using the Hailer.....	21
<b>How It Works .....</b>	<b>5</b>	Using the Foghorn.....	22
Normal Mode .....	6	<b>Installing the Hardware .....</b>	<b>23</b>
Scan Mode .....	7	Mounting the Radio .....	23
Weather Mode .....	8	Using the Flush Mount Bracket.....	23
<b>Using Your Radio .....</b>	<b>9</b>	Connecting the Radio.....	24
Using the Menu.....	9	Connecting to a GPS Receiver .....	25
Making a Voice MAYDAY Call .....	9	Connecting to a Chartplotter .....	26
Setting the Volume .....	9	Connecting to an External Speaker .....	26
Setting the Squelch Level .....	9	<b>Maintenance and Troubleshooting .....</b>	<b>27</b>
Changing the Channel .....	9	Performing a Self Test .....	28
Renaming Channels .....	9	Engine Noise Suppression .....	28
Making a Transmission.....	10	<b>Specifications .....</b>	<b>28</b>
Choosing Triple Watch or Dual Watch .....	11	<b>Reference Tables .....</b>	<b>29</b>
Using FIPS Codes for Weather Alerts.....	11	Channel Descriptions and what They Mean .....	29
Using the Scrambler .....	12	NMEA Operation .....	34
Changing Display and Sound Options .....	12	NMEA Output .....	34
Setting the GPS Position Manually .....	13	<b>Regulations and Safety Warnings .....</b>	<b>34</b>
<b>Using Digital Selective Calling (DSC) Features .....</b>	<b>13</b>	<b>Three Year Limited Warranty Statement .....</b>	<b>35</b>
What Is DSC? .....	13		
Entering MMSI Numbers in Your Radio .....	14		
Using the Directory .....	15		

## INTRODUCTION

### Radio Features

- Submersible design
- Large, dot matrix display
- Advanced DSC Class D functions, including Test Calling
- Channel select buttons on the microphone
- Memory scan mode – Lets you save channels to memory and monitor them in quick succession.
- Transmitter power level select – Lets you boost the transmitter power from 1 watt to 25 watts for added transmission distance.
- Battery level display and tone – Sounds an alert tone if the battery voltage goes too high or too low.
- Triple watch operation – Checks the Coast Guard Distress/Hailing channels 16 and 9 in the background.
- All marine VHF channels for the U.S., Canada, and international waters
- National Oceanic and Atmospheric Administration (NOAA) weather channel watch – Checks the local NOAA weather channel in the background and sounds a warning tone if a hazard alert is issued.

# GETTING STARTED

## What's Included



VHF680 DSC radio

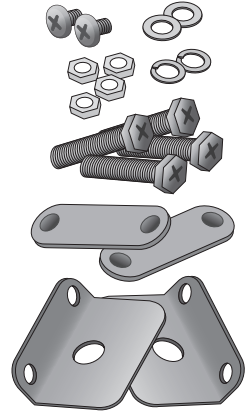

Flush mount bracket kit

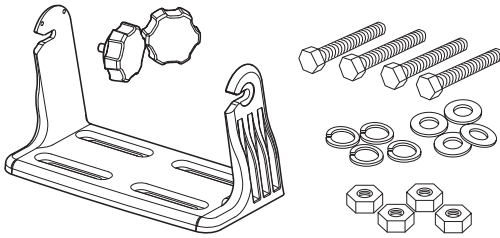

Mounting bracket, knobs, and hardware

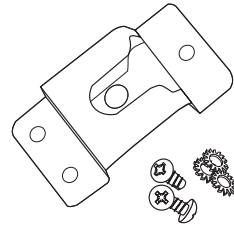

Microphone hanger and mounting hardware

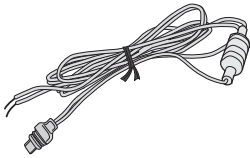

DC power cord

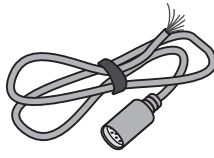

Hailer cable



Accessory cable

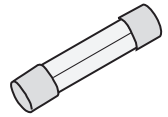

Spare fuse

# Parts of the Radio

## Front view

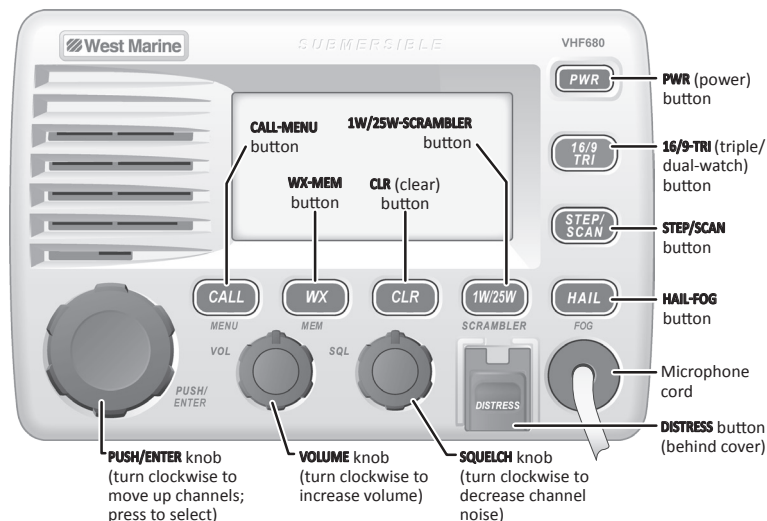

Button/Knob	Press/Turn to...	Press and hold to...
<b>PUSH/ENTER</b>	Press to choose an option on a menu or to display the GPS data. Turn to move up and down channels.	NA
<b>VOL</b>	Turn to increase or decrease volume.	NA
<b>SQL</b>	Turn clockwise to decrease channel noise.	NA
<b>DISTRESS</b>	Select the nature of your distress for a distress call.	Transmit a distress call.
<b>CALL-MENU</b>	Open the call menu.	Open the normal menu (see page 9).
<b>WX-MEM</b>	Listen to the current weather conditions in your area.	Save a channel into memory or remove a channel from memory.
<b>CLR</b>	Go to previous menu or move the cursor back one space.	NA
<b>1W/25W-SCRAMBLER</b>	Change the transmit power (see page 10).	Activate the voice scrambler (see page <?>).
<b>PWR</b>	Turn the radio on and off.	NA
<b>16/9-TRI</b>	1 <sup>st</sup> press: Go to Channel 16. 2 <sup>nd</sup> press: Go to Channel 9. 3 <sup>rd</sup> press: Go back to the original channel.	Go into Triple Watch or Dual Watch mode (see page 7)..
<b>STEP/SCAN</b>	Go to the next channel in memory.	Start scanning the channels saved in memory.
<b>HAIL-FOG</b>	Activate the hailing speaker.	Display the fog horn menu (see page 21).

## Rear view

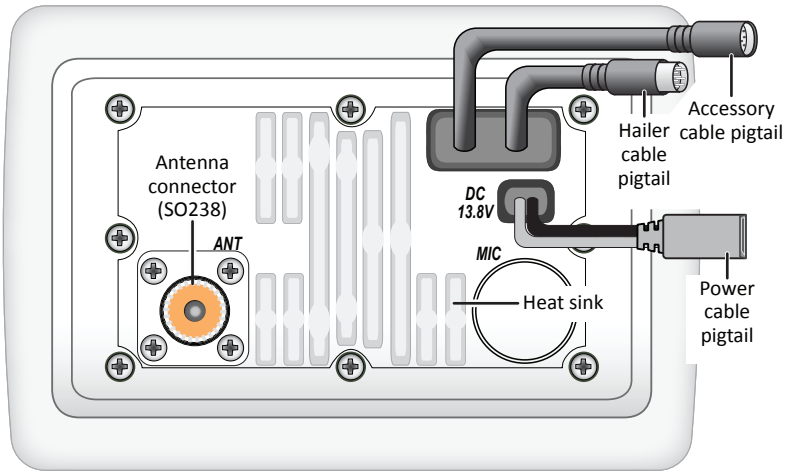

Connector	Connects to...	For details, see ...
Antenna connector	External VHF antenna with a male PL259 (SO238) connector and 50 $\Omega$ impedance. Minimum 4 ft, 3dB rated antenna for sailboats, 8 ft, 6 dB rated for power boats.	Connecting the radio (see page 24).
Power cable pigtail	Nominal 13.8 VDC power supply with negative ground (10.4 VDC to 15.8 VDC).	Connecting the radio (see page 24).
Accessory cable pigtail	A GPS receiver, a chartplotter, and an external monitoring speaker.	Connecting a GPS (see page 25).
Hailer cable pigtail	A hailing speaker or fog horn.	Connecting an optional hailing speaker (see page 26).

## Microphone

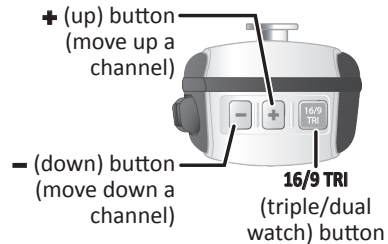

Button	Press to...	Press and hold to...
( + )	Move up one channel at a time.	Move quickly up the channels.
( - )	Move down one channel at a time.	Move quickly down the channels.
16/9-TRI	1 <sup>st</sup> press: Go to Channel 16. 2 <sup>nd</sup> press: Go to Channel 9. 3 <sup>rd</sup> press: Go back to the original channel.	Go into Triple Watch or Dual Watch mode (see page 7).
PUSH-TO-TALK	Cancel scanning and stay on a channel.	Talk on a channel.



## Turning on the Radio

Press **PWR** to turn on the radio. As it powers on, the radio displays the user MMSI number, then goes to the last channel used.

 If there is no MMSI set, the radio displays *MMSI not entered*. See page 14 for information on entering MMSI number.

## Setting the UIC Channel Mode (USA/CAN/INT)

The radio comes preset to use the UIC channels assigned for the United States. If you are operating in an area that uses Canadian or international UIC channels, you will need to change the channel mode.

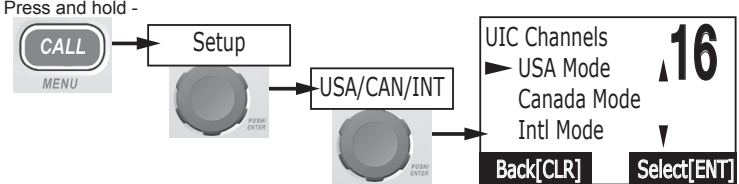
1. Press and hold **CALL-MENU** to open the menu, and choose the *Setup* sub-menu.
 
2. Select *USA/CAN/INT*. The screen displays the UIC channel setup.
3. Choose the channel mode you want to use: US (*USA Mode*), Canadian (*Canada Mode*), or international (*Intl Mode*).
4. Press **PUSH/ENTER**. The radio activates the new channel mode and exits the menu.

## Checking the UIC channel mode with your GPS

If you connect your radio to a GPS receiver (see page 25), the radio can use the data from the GPS to verify the UIC channel mode setting.

1. Press and hold **CALL-MENU** to open the menu.
2. Select the *GPS Setup* sub-menu, then choose *UIC Waters*.
3. Choose *12 Miles* to have the radio use a margin of error of about 12 miles; choose *200 Miles* to have the radio use a margin of error of about 200 miles.
4. Press **PUSH/ENTER**. The radio activates the new setting and returns to *GPS Setup* menu.

The radio compares the location received from the GPS against areas known to use US, Canadian, or international channels (within the margin of error selected above). If the programmed UIC channel mode you does not match the mode used in the current area, the radio displays an alert along with the correct channel mode.

## HOW IT WORKS

Your radio has three basic modes of operation:

Mode	What it does	Use it when	To turn it on/off...
Normal	Monitors a single marine radio channel and lets you talk on that channel.	You want to talk to another station on a specific channel.	(default mode)
Scan	Monitors all the channels you save into memory.	You have a small group of channels you use most often and want to check them for traffic.	Press and hold <b>STEP/SCAN</b> .
Weather	Monitors the selected NOAA weather channel.	You want to hear the current and forecasted weather in your area.	Press <b>WX-MEM</b> .

In addition to the three basic operation modes, your radio also provides three different “watch” modes which you can activate during any of the three basic modes. In these watch modes, the radio briefly checks for activity on a specific channel then returns to its previous mode.

Watch mode	What it does	Use it when	To turn it on/off...
Weather Alert	Checks for alerts on the last-used weather channel every 7 seconds.	You want to be made aware of severe weather conditions in your area.	Select <i>WX Alert Mode</i> in the <i>Setup</i> menu, and then choose <i>ON</i> or <i>OFF</i> .
Triple	Checks for activity on channels 16 and 9 every 2 seconds.	You want to monitor a channel yet maintain a watch on channels 16 and 9.	Press and hold <b>16/9-TRI</b> for 2 seconds.
Dual	Checks for activity on channel 16 every 2 seconds.	You want to monitor a channel yet maintain a watch on channel 16.	Change <i>Triple Watch</i> to <i>Dual Watch</i> in the <i>Setup</i> menu, then press and hold <b>16/9-TRI</b> for 2 seconds.

 **NOTE: You are required to monitor channel 16 whenever your boat is underway. You should have either Triple Watch or Dual Watch on at all times.**

## Normal Mode

Normal mode lets you monitor and transmit on whatever channel you select. In normal mode, the radio displays the information shown to the right (not all indicators display at the same time).

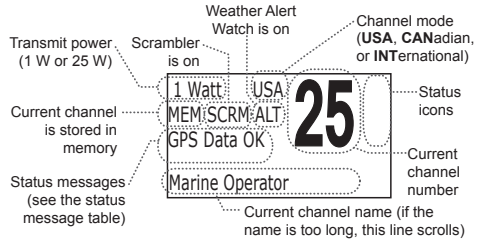

Message	Meaning
<i>GPS Data OK</i>	The radio is receiving valid GPS data.
<i>Check GPS</i>	The radio is not receiving valid GPS data: check the GPS status screen and the GPS connection.
<i>Input Position</i>	The radio has been unable to receive valid GPS data for at least four hours; it can no longer track your position. You need to manually input your position (see <i>Setting the GPS Position Manually</i> on page 13).
<i>BATTERY LOW</i>	The battery voltage output is too low (below 10.4 VDC).
<i>BATTERY HIGH</i>	The battery voltage output is too high (above 15.8 VDC).
<i>USA, CAN, or INT Area</i>	The channel mode setting does not match the channel mode ( <i>USA</i> , <i>CAN</i> adian, or <i>INT</i> ernational) normally used in the current location (based on data provided by the GPS).
<i>HAIL ERROR</i>	The hailer speaker is not connected properly.
<i>Auto Fog, Manual Fog, Underway Fog, Stop Fog, Sail Fog, Tow Fog, Anchor Fog, Aground Fog, or Yelp Fog</i>	The type of tone or signal used by the fog horn (see page 21).

## Using the radio in normal mode

- To transmit, press and hold **PUSH-TO-TALK** on the microphone. Release the button when you are finished talking.
- For the best sound quality, hold the microphone about 2 inches from your mouth while you're talking.
- Turn the **PUSH/ENTER** knob clockwise to move up the channels. Turn it counter-clockwise to move down the channels.
- To change the transmit power, press **1W/25W-SCRAMBLER**. The transmit power switches between 1 Watt and 25 Watts each time you press **1W/25W-SCRAMBLER**.

## Normal mode with Weather Alert Watch

If you activate Weather Alert Watch while operating in normal mode, the radio checks the most recently-used weather channel every 7 seconds. If it detects a weather alert, it will change the channel to the last-used weather channel. The radio will not check the weather channel while you are actively transmitting; it waits until your transmission is finished and then checks the weather channel.

To turn Weather Alert Watch on or off, press and hold **CALL-MENU** while the radio is idle. Select *Setup* and then *WX Alert Mode*. Turn the **PUSH/ENTER** knob to choose *On* or *Off*, and press **PUSH/ENTER** to select.

### Normal mode with Triple and Dual Watch

If you activate Triple Watch while operating in normal mode, the radio checks channels 16 and 9 every 2 seconds; with Dual Watch turned on, the radio only checks channel 16. The radio will not check channels 16 or 9 while you are actively transmitting; it waits until your transmission is finished and then checks the channels.

Press and hold **16/9-TRI** (on the radio or the microphone) for 2 seconds to turn Triple/Dual Watch on or off. (To change between Triple or Dual Watch, see page 11.)

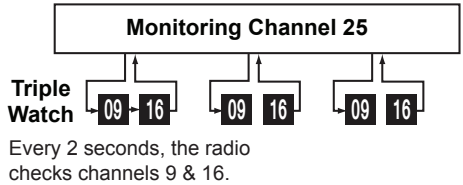

### Normal mode with both Weather Alert and Triple/Dual Watch

You can activate Weather Alert Watch and Triple/Dual Watch at the same time. The radio performs both checks at their scheduled time.

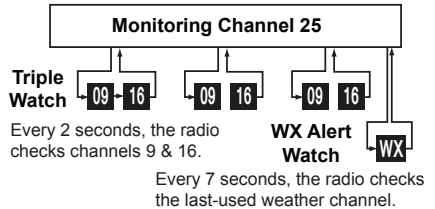

### Scan Mode

You can save channels into memory and then use scan mode to monitor those channels. When the radio detects a signal on a channel, it pauses on that channel as long as the signal is received; when the transmission stops, the radio will continue scanning.

In scan mode, the radio displays the information shown to the right (not all indicators display at the same time).

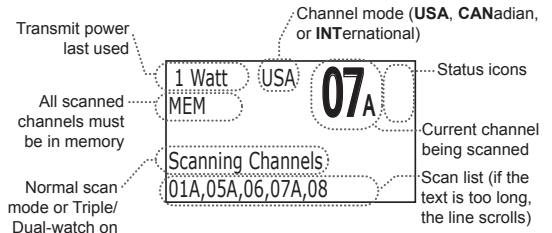

### Using the radio in scan mode

- You cannot transmit while in scan mode.
- You must have 2 or more channels in memory to start a scan.
- To save a channel into memory, select the channel, then press and hold **WX-MEM** for 2 seconds. *MEM* will show on the display.
- To remove a channel from memory, set the radio to that channel, then press and hold **WX-MEM** for 2 seconds. *MEM* will no longer show on the display.
- To activate scan mode, press and hold **STEP/SCAN**. Press and hold **STEP/SCAN** again to return to the previous mode.
- When the radio automatically stops on a channel, turn the **PUSH/ENTER** knob clockwise to leave that channel and resume scanning.

### Scan mode with Weather Alert Watch

If you activate Weather Alert Watch while operating in scan mode, the radio checks the most recently-used weather channel every 7 seconds, then continues scanning the next channel in memory.

To turn Weather Alert Watch on or off, press and hold **CALL-MENU** while the radio is idle. Select *Setup* and then *WX Alert Mode*. Turn the **PUSH/ENTER** knob to choose *On* or *Off*, and press **PUSH/ENTER** to select.

### Scan mode with Triple and Dual Watch

If you activate Triple Watch while operating in scan mode, the radio checks channels 16 and 9 every 2 seconds, then goes on to scan the next channel; with Dual Watch turned on, the radio only checks channel 16.

To activate Triple/Dual Watch with scan mode:

1. Turn off scanning mode.
2. Press and hold **16/9-TRI** (on the radio or the microphone) for 2 seconds. (To change between Triple or Dual Watch, see page 11.)
3. Activate scan mode (press and hold **STEP/SCAN**).

## Scan mode with both Weather Alert and Triple/Dual Watch

You can activate Weather Alert Watch and Triple/Dual Watch at the same time. The radio performs both checks at their scheduled time.

## Weather Mode

In cooperation with the FCC, NOAA also uses the weather channels to alert you of other hazards besides weather (child abduction alerts, nuclear, biological, etc.). In weather mode, the radio monitors one of the ten NOAA weather channels. In weather mode, the display shows the following:

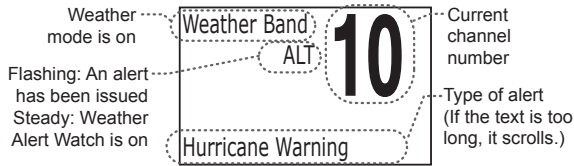

## Using the radio in weather mode

- You cannot transmit while in weather mode.
- To enter weather mode, press **WX-MEM**.
- To cancel weather mode and return to the previous marine channel, press **WX-MEM**.

## Weather mode with Weather Alert Watch

Because weather mode already monitors the weather channels, you don't need Weather Alert Watch to check the weather channel every 7 seconds. If you activate Weather Alert Watch while operating in weather mode, it operates as a type of "sleep mode". This mode is very useful when you are anchoring for the night but want to stay informed of any hazards in your area:

- The radio stays on the weather channel and mutes the speaker. If it detects an alert for your area, the radio sounds an alert tone and turns the speaker back on.
- In order to filter out alerts that do not affect your area, you must have at least one location code (FIPS code) programmed into your radio (see page 11). If the FIPS code of the alert matches a FIPS code entered in your radio, the radio will sound the alert.
- To turn off the radio's alert tone, press any button.

To turn Weather Alert Watch on or off, press and hold **CALL-MENU** while the radio is idle. Select *Setup* and then *WX Alert Mode*. Turn the **PUSH/ENTER** knob to choose *On* or *Off*, and press **PUSH/ENTER** to select.

## Weather mode with Triple and Dual Watch

If you activate Triple Watch while operating in weather mode, the radio checks channels 16 and 9 every 2 seconds; with Dual Watch turned on, the radio only checks channel 16.

Press and hold **16/9-TRI** (on the radio or the microphone) for 2 seconds to turn Triple/Dual Watch on or off. (To change between Triple or Dual Watch, see page 7.)

## Memory Channel Scan

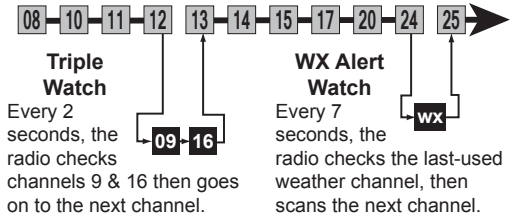

## Monitoring Weather Channel WX08



Every 2 seconds, the radio checks channel 9, then channel 16.

# USING YOUR RADIO

## Using the Menu

To open the radio call menu, press **CALL**. To open the normal menu, press and hold **CALL-MENU**. The options on the normal menu are shown to the right.

- An arrow on the left side indicates the current selection.
- Turn the **PUSH/ENTER** knob counter-clockwise to move up a line in the menu; turn it clockwise to move down a line. If you are at the top (or bottom) line in the menu, the cursor jumps to the bottom (or top) of the menu.
- Press **PUSH/ENTER** to choose the selected item.
- Press **CLR** to go back to the previous menu screen.
- From any menu screen, choose **[Exit]** or press and hold **CALL-MENU** to close the menu screen.

Press and hold -

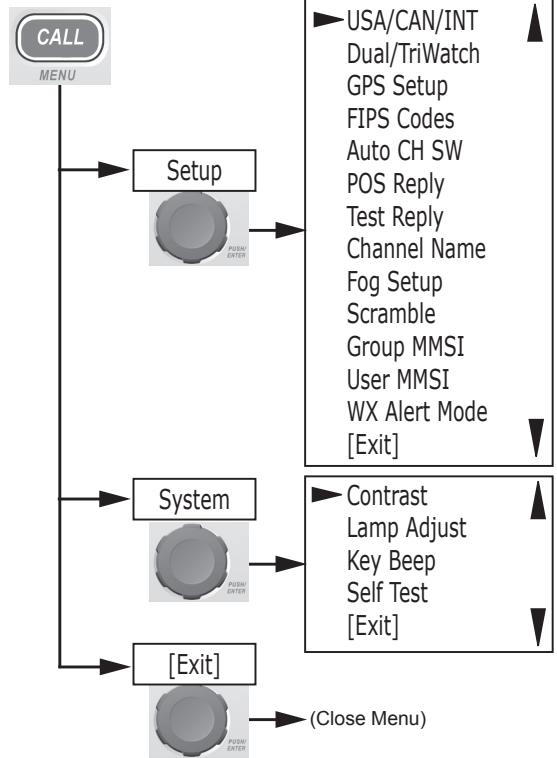

## Making a Voice MAYDAY Call

(see inside front cover)

## Setting the Volume

Turn the **VOL** knob clockwise to increase the speaker volume; turn it counter-clockwise to decrease the volume.

## Setting the Squelch Level

The squelch feature reduces the level of static on the speaker by filtering out any background channel noise. At the lowest squelch level, the speaker plays all radio signals, including any noise on the channel. Setting the squelch level higher filters out channel noise and lets only actual radio transmissions through.

While listening to a channel, adjust the **SQL** knob until the noise is filtered out and you can only hear the transmission. If you switch to a channel with a lot of noise or with a weak transmission, you may need to adjust the squelch level again.

 **NOTE:** Setting the squelch level too high may prevent you from hearing weaker transmissions. If you are having difficulty hearing a transmission, try setting the squelch level lower.

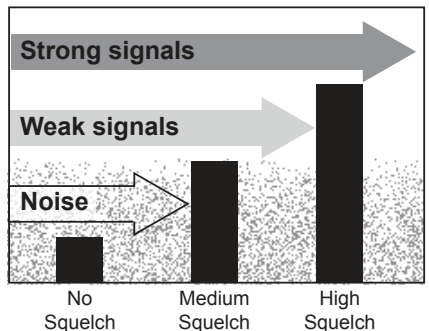

## Changing the Channel

Turn the **PUSH/ENTER** knob clockwise to go up the channels; turn it counter-clockwise to go down the channels.

## Renaming Channels

If you discover that a marine radio channel has a different common name in your local area, you can change the name of that channel to make it easier for you to use (see the channel lists beginning on page **41** for the default channel names). To rename a channel, follow the steps below:

1. Open the normal menu and choose the *Setup* sub-menu.
2. Select *Channel Name*. The screen displays the list of channels.

3. Turn the **PUSH/ENTER** knob to select the channel you want to change and press **PUSH/ENTER**.
4. Select *Rename* to enter a new name for this channel. The radio prompts you to enter a new name for this channel. Each name can be up to 12 characters.
5. Turn the **PUSH/ENTER** knob to change the first character. When the first character is correct, press **PUSH/ENTER**. The cursor moves to the next character.
6. Enter the remaining 11 characters of the name. If the name is shorter than 12 characters, press and hold **PUSH/ENTER** to complete the entry. If you make a mistake, press **CLR** to erase the wrong character.
7. When you finish entering the name, the radio displays the new channel name and asks you to confirm. To save this new channel name, select *Yes*; to cancel the change, select *No*. The radio returns to the channel list.
8. To restore a channel to its original name, select the channel and choose *Default*.
9. When you are satisfied with the channel list, select *[Exit]* to close the menu.

## Making a Transmission

To make a transmission, press and hold **PUSH-TO-TALK** on the microphone. Release **PUSH-TO-TALK** when you're finished talking to let the other party respond.

- To prevent stuck microphone problems or situations where **PUSH-TO-TALK** is pushed accidentally, the radio limits your talk time to 5 minutes in a single transmission. If you talk for over 5 minutes continuously, the display shows *RELEASE MIC BUTTON*.
- For the best sound quality, hold the microphone about 2 inches away from your mouth.
- You cannot transmit while the radio is in weather mode or scan mode.
- See the channel lists beginning on page 29 for a list of receive-only channels.

## Boosting the transmission power

In most situations, the 1 Watt transmission power is all you need. If you find yourself far away from other stations and have trouble getting a response, you may need to boost the transmission power from 1 Watt to 25 Watts:

1. Select the channel you want to transmit on.
2. Press **1W/25W-SCRAMBLER**. The display shows *25 Watts*.
3. The transmit power remains at 25 Watts until you change the setting back. Press **1W/25W-SCRAMBLER**. The display shows *1 Watt*.

 **NOTE: Don't forget to change the transmission setting back to 1 Watt when you move closer to other stations.**

 **NOTE: By default, when you change to channel 16, the radio automatically boosts the power to 25 Watts. Be sure to change the power back to 1 Watt if you are not making an emergency transmission.**

Some channels (for example, channels 13 and 67) limit the transmit power to 1 Watt so that there is less interference between boaters attempting to use the channel at the same time. If you switch to one of these channels, the radio changes back to 1 Watt automatically. See the channel lists beginning on page 29 for a list of power-restricted channels.

## Boosting the power during a transmission

You can also boost the transmission power in the middle of a transmission. While you're talking, press **1W/25W-SCRAMBLER**. The radio changes back to 1 Watt when your transmission ends.

 **This operation is invalid for CH75 and CH76.**

## Choosing Triple Watch or Dual Watch

In Triple Watch mode, the radio checks channels 16 and 9 every 2 seconds; in Dual Watch mode, the radio checks channel 16 only. Generally, Triple Watch is used in areas where channel 9 is used as a hailing frequency; Dual Watch is used in areas where channel 16 is used for distress and hailing. Your radio comes set to use Triple Watch; if you want to use Dual Watch, you will have to change the setup.

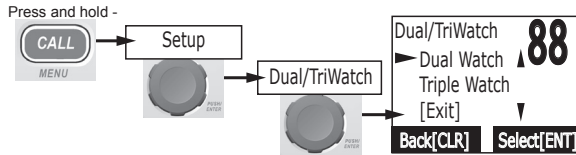

Press and hold **CALL-MENU** to open the normal menu.

4. Select *Setup* and then *Dual/TriWatch*.
5. Choose *Dual Watch* and press **PUSH/ENTER**. The radio activates the new setting and returns to the *Setup* menu.
6. To reactive Triple Watch, repeat the procedure described above, but choose *Triple Watch* in step 3.

## Using FIPS Codes for Weather Alerts

The US National Weather Service established 6-digit Federal Information Processing System (FIPS) codes to issue weather alerts in specific areas. You can choose which areas you want to hear alerts for by entering these FIPS codes in your radio. This can prevent you from being bothered by events that are far from where you are boating. The radio only sounds the alert tone if an incoming FIPS code matches one of the areas you selected.

- For more information about how the NWS uses FIPS codes, see the NWS website: [www.nws.noaa.gov/nwr/nwsfipschg.htm](http://www.nws.noaa.gov/nwr/nwsfipschg.htm).
- To see an index of FIPS codes by state, see the website of the National Institute of Standards and Technology (NIST): [www.itl.nist.gov/fipspubs/co-codes/states.htm](http://www.itl.nist.gov/fipspubs/co-codes/states.htm).
- For information on the Canadian implementation of FIPS codes, called Canadian Location Codes, see the website of the Meteorological Service of Canada (MSC): [http://www.msc.ec.gc.ca/msb/weatheradio/transmitter/index\\_e.cfm](http://www.msc.ec.gc.ca/msb/weatheradio/transmitter/index_e.cfm)

 **NOTE:** If you travel outside the areas you have entered into your radio, you may not hear alerts that affect your new location. Be sure to enter the FIPS codes of all the areas you plan to travel to during this trip.

Follow the steps below to edit the list of FIPS codes. You can store up to 30 different FIPS codes in your radio.

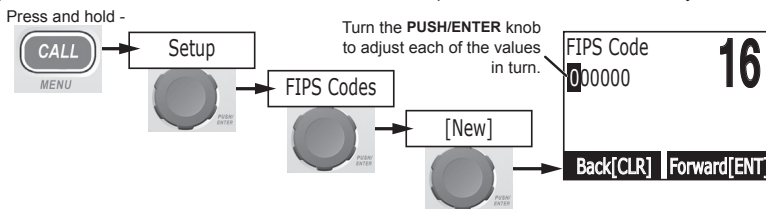

1. Open the normal menu and choose the *Setup* sub-menu.
2. Select *FIPS Codes*. The screen displays any previously-entered FIPS codes.
3. To add a new FIPS code, select *[New]*.
4. Use the **PUSH/ENTER** knob to change the first of the six digits; turn it clockwise to increase the number or counter-clockwise to decrease it.
5. When the first digit is correct, press **PUSH/ENTER**. The cursor moves to the next digit. Enter the remaining five digits of the FIPS code in the same way. If you make a mistake while entering a digit, press **CLR** to erase the wrong digit.
6. When the sixth digit is correct, press **PUSH/ENTER**. The radio displays the new FIPS code and asks you to confirm. To save this code, select *Yes*; to cancel this code, select *No*. The radio returns to the list of FIPS codes.

7. If you are satisfied with the list of FIPS codes, select *[Exit]* to close the menu.  
OR  
To edit an existing FIPS code, select the code you want to change from the list.
8. To delete the FIPS code, select *Delete*. To edit the code, select *Edit*, then use the **PUSH/ENTER** knob to change each of the six digits as described above.
9. When you are finished, select *[Exit]* to close the menu.

## Using the Scrambler



**NOTE: This feature requires the installation of an optional scrambler board. Contact your dealer for more information.**

The scrambler feature allows you to talk privately with other radios; only radios that have the same scrambler code will be able to decode your transmissions.

### Setting the scrambler code

Your radio must use the same scrambler code as any radios you want to speak to.

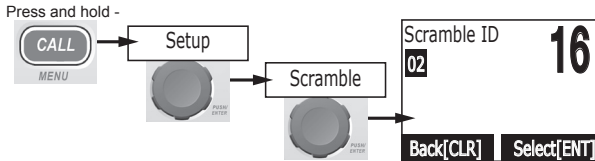

1. Open the normal menu and choose the *Setup* sub-menu.
2. Select *Scramble*.
3. Turn the **PUSH/ENTER** knob to select one of the 32 available scrambler codes, and press **PUSH/ENTER**.

### Activating scrambler mode

To send a scrambled transmission, select the channel you want to transmit on, then press and hold **1W/25W-SCRAMBLER** for 2 seconds. Any transmissions you send on that channel will be scrambled until you turn the scrambler feature off. (To turn off the scrambler feature, press and hold **1W/25W-SCRAMBLER** again.)



**The scrambler function is automatically disabled on channel 16; in USA channel mode, the scrambler function is also disabled on channels 9 and 15.**

## Changing Display and Sound Options

### Contrast

Your radio display has 10 levels of contrast. To adjust the contrast, press and hold **CALL-MENU** while the radio is idle. Select *System* and then *Contrast*. Turn the **PUSH/ENTER** knob to change the contrast to your desired level.

To restore the default contrast setting, turn the radio off. Press **CALL-MENU** and hold it in while you turn the radio on.

### Lamp adjust

Your radio has 10 brightness levels on the display. To adjust the brightness, press and hold **CALL-MENU** while the radio is idle. Select *System* and then *Lamp Adjust*. Turn the **PUSH/ENTER** knob to change the brightness to your desired level.

### Changing the key beep volume

Key beep is the tone that sounds when you press a key or a button. To change the volume of the key beep, press and hold **CALL-MENU** while the radio is idle. Select *System* and then *Key Beep*. Choose a volume level (1 through 4), or select level 0 to turn off the key beep.



# Setting the GPS Position Manually

Any time the radio does not receive valid GPS data for four hours, it displays *Input Position*. If the GPS is also connected, the radio will sound an alert tone as well as display *Input Position*. Follow the steps below to manually input your position.

 **NOTE: Be certain any manually-entered position is correct. If you enter the wrong position and then make a DSC distress call, you will be sending the incorrect location to rescuers.**

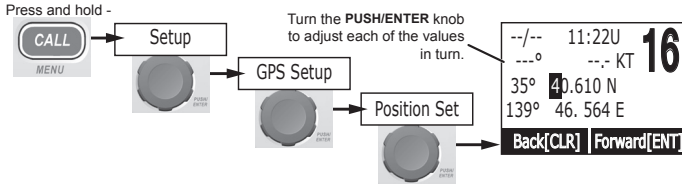

1. Open the normal menu and choose the *Setup* sub-menu.
2. Select *GPS Setup* and then choose *Position Set*. The radio displays the GPS manual input screen and highlights the time setting.
3. Use **PUSH/ENTER** to set the time to match coordinated universal time (UTC, also call Greenwich Mean Time and Zulu Time). This is not your local time!
  - Turn the **PUSH/ENTER** knob until the displayed hour matches UTC, then press **PUSH/ENTER**. The cursor moves to highlight the minutes.
  - Turn the **PUSH/ENTER** knob until the displayed minutes match UTC, then press **PUSH/ENTER**. The cursor moves to highlight the degrees latitude.
  - If you make a mistake, press **CLR** to erase the wrong number.
4. Use **PUSH/ENTER** to set the latitude.
  - Turn the **PUSH/ENTER** knob to set the degrees latitude, then press **PUSH/ENTER**. The cursor moves to highlight the minutes latitude.
  - Turn the **PUSH/ENTER** knob to set the minutes latitude, then press **PUSH/ENTER**. The cursor moves to highlight *N*.
  - Turn the **PUSH/ENTER** knob to select *North* or *South* latitude, then press **PUSH/ENTER**.
5. Follow the same procedure to set the degrees and minutes longitude, then select *East* or *West*.
  - Turn the **PUSH/ENTER** knob to adjust each value, then press **PUSH/ENTER** to update the setting. As you update each value, the cursor moves to the next value in turn.
  - When you enter the last value, the radio returns to the *GPS Setup* menu.
  - If you make a mistake, press **CLR** to erase the wrong number

## USING DIGITAL SELECTIVE CALLING (DSC) FEATURES

### What Is DSC?

Digital Selective Calling (DSC) is a standard that allows you to call other stations using a unique identification code, the Maritime Mobile Service Identity (MMSI) number. To call another station, just enter that station's MMSI number and choose the voice channel you want to talk on. The radio uses channel 70 to transmit your MMSI number to the other station along with the voice channel you requested. If the other station accepts your call, both stations switch their radios to the requested voice channel so you can talk to each other station. (Your radio switches automatically; to turn off the automatic channel switch, see page 21.)

DSC provides a system for automated distress calls. At the touch of a button, the radio can transmit your MMSI number, the nature of your distress, and your current position based on data from your GPS receiver. The radio repeats the distress call every few minutes until it receives an acknowledgement.

The DSC standard dedicates a VHF channel—channel 70—to digital transmissions only. Since digital transmissions require less bandwidth voice transmissions, channel 70 avoids the problems of busy voice channels.

# Advanced DSC features

Your radio supports the following DSC features:

Feature	Menu Item	Function
Individual Call	Individual	Contact another vessel from your directory.
Group Call	Group	Contact all vessels that share your group MMSI code.
All Ships Call	All Ships	Broadcast to all vessels within range (used for safety or advisory messages).
Position Request	POS Request	Request the current location of another vessel.
Position Send	Position Send	Transmit your current location to another vessel.
Test Call	Test	Make sure your radio is working and configured correctly.
Name and MMSI Directory	Directory	Store a list of 20 names and MMSI numbers for DSC calls.
Standby Mode	Standby	Automatically respond to all DSC calls within an "Unavailable" status.
Received Call Log	Receive Log	Display the last 10 distress calls received by the radio and the last 50 general calls.

## Entering MMSI Numbers in Your Radio

### What is an MMSI number?

In order to use DSC features, you must be assigned an MMSI number and program that number into your radio. There are 2 kinds of MMSI numbers: individual numbers for use by single boats and group numbers for use by fleets, boating organizations, event coordinators, etc.

You can get more information on MMSI numbers at these resources:

- The dealer where you purchased the radio
- Recreational boaters can contact the Boat Owner's Association of the U.S. (<http://www.boatus.com/mmsi/> or call 800-536-1536) or Sea Tow Services International ([http://seatow.com/boating\\_safety/mmsi.asp](http://seatow.com/boating_safety/mmsi.asp))
- Commercial boaters need a ship station license to get an MMSI number. For more information, visit the Federal Communications Commission (FCC) website at <http://wireless.fcc.gov/marine/ftsht14.html>.

### Individual or User MMSI number



**NOTE: Be sure you have the correct User MMSI number before entering it in the radio. You can only enter a user MMSI once. If you need to change the number, contact customer service (see back page for contact information).**

Follow the steps below to enter your individual/user MMSI number into the radio:

1. Open the normal menu and choose the *Setup* sub-menu.
2. Select *User MMSI*. (If an MMSI number was already entered, the screen displays the number with the message *Cannot change over 1 time*. Contact customer service. (See back page for contact information).)
3. Use the **PUSH/ENTER** knob to change the first of the nine digits; turn it clockwise to increase the number or counter-clockwise to decrease it.
4. When the first digit is correct, press **PUSH/ENTER**. The cursor moves to the next digit. Enter the remaining eight digits of the MMSI number in the same way. If you make a mistake, press **CLR** to erase the wrong digit.
5. After you enter the ninth digit, the radio displays the new MMSI number and asks if you want to save it. To save this MMSI number, select *Yes*. (Select *No* to cancel without saving; the radio returns to the *Setup* menu.)

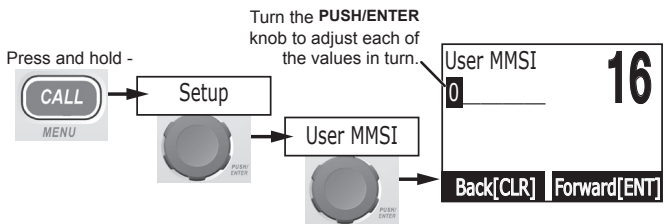

- The radio reminds you that this is a permanent setting and asks you to confirm. To confirm the entry, press **PUSH-ENTER**. The radio returns to the *Setup* menu.  
OR  
Press **CLR** to return to the MMSI edit screen.

## Group MMSI number

You can change the group MMSI number as often as you want. Follow the steps below to enter a group MMSI number into the radio:

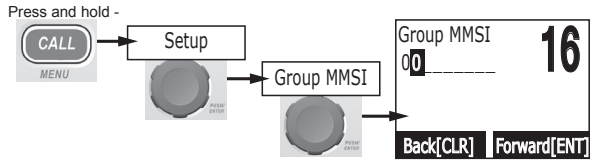

- Open the normal menu and choose the *Setup* sub-menu.
- Select *Group MMSI*. If one was entered previously, the screen displays it.
- Group MMSI numbers always start with a 0, so that digit is already entered for you. Use the **PUSH/ENTER** knob to change the second digit; turn it clockwise to increase the number or counter-clockwise to decrease it.
- When the second digit is correct, press **PUSH/ENTER**. The cursor moves to the next digit. Enter the remaining seven digits of the MMSI number in the same way. If you make a mistake, press **CLR** to erase the wrong digit.
- When the ninth digit is correct, press **PUSH/ENTER**. The radio displays the new MMSI number and asks you to confirm.
- To save this MMSI number, select *Yes* and confirm the entry. To cancel this MMSI number, select *No*. The radio returns to the *Setup* menu.

## Using the Directory

The directory lets you store up to 20 MMSI numbers of other stations so you can call them quickly. Follow the steps below to edit MMSI numbers in your directory.

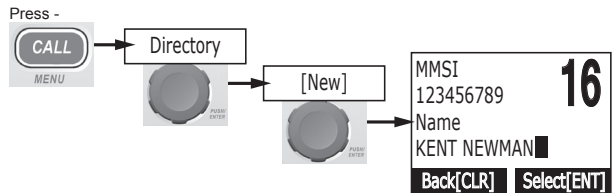

- Press **CALL-MENU** to open the call menu, and select *Directory*. The screen displays any previously-entered MMSI numbers and names.
- To add a new MMSI number to the directory, select *[New]*.
- The radio prompts you to enter the nine-digit MMSI number. Use the **PUSH/ENTER** knob to change the first digit; turn it clockwise to increase the number or counter-clockwise to decrease it.
- When the first digit is correct, press **PUSH/ENTER**. The cursor moves to the next digit. Enter the remaining eight digits of the MMSI number in the same way. If you make a mistake, press **CLR** to erase the wrong number.
- When the ninth digit is correct, press **PUSH/ENTER**.
- The radio prompts you to enter a name (up to 12 characters) for this MMSI number; the name displays in the directory list. Turn the **PUSH/ENTER** knob to scroll through the available characters according to the following table:

Clockwise	Counter-clockwise
Capital letters (A through Z)	One blank space
Lower-case letters (a through z)	Numbers (0 through 9)
Punctuation (/ ' + -)	Punctuation (/ ' + -)
Numbers (0 through 9)	Lower-case letters (a through z)
One blank space	Capital letters (A through Z)

- When the first character is correct, press **PUSH/ENTER**. The cursor moves to the next character.
- Enter the rest of the 11 characters the same way. If the name is shorter than 12 characters, press and hold **PUSH/ENTER** to complete the name entry. (If you press and hold **PUSH/ENTER** without entering a name, the radio displays the MMSI number in the directory list.)
- When you finish entering the name, the radio displays the new MMSI number and name and asks you to confirm. To save this directory entry, select *Yes*; to cancel this directory entry, select *No*. The radio returns to the directory list.

10. To change an existing directory entry, select the entry you want to change.
11. To delete the directory entry, select *Delete*. To edit the code, select *Edit*, then use the **PUSH/ENTER** knob to edit the MMSI number and the name.
12. When you are satisfied with the directory list, select [*Exit*] to close the menu.

## Making DSC Calls

There are essentially four different types of DSC voice calls:

Call type	What it does	When to use it
Distress	Alerts all stations that you need assistance and sends them your current position.	In an emergency only.
Individual	Calls a single station using the User MMSI.	Any time you want to talk to another station.
Group	Calls all the stations that have the same Group MMSI as yours.	Any time you want to speak with the whole group at the same time.
All Ships	Calls all stations within range of your radio.	Safety warnings (e.g., debris in the water) or any urgent situation.

For example, here are some ways you might use DSC calling if you were coordinating safety for a sailboat race:

- Before the race starts, you instruct all the racers and any spectator boats to enter your group MMSI number into their radios.
- Throughout the race, you use group calling to update the racers on the time, race status, and any course corrections.
- A power boat full of spectators comes too close to the race path. You use individual calling to contact the power boat and advise them to stay clear of the race.
- You see a rowboat entering the area, but since it doesn't have a radio, you can't communicate with it. You use all ships calling to alert all the other boats in the area of the possible danger.

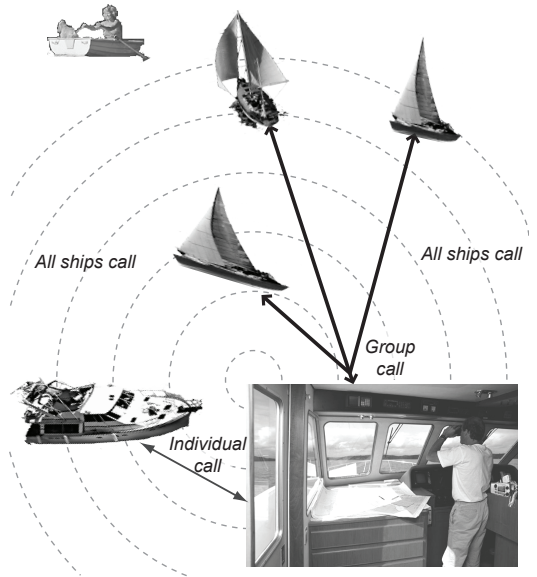

### Calling a single station (Individual Call)

1. Press **CALL-MENU** to open the call menu, and select *Individual*.
2. The radio displays the names listed in your directory; turn the **PUSH/ENTER** knob to choose the directory entry you want to call and press **PUSH/ENTER**.
  - If you want to call a station that is not in your directory, select [*Manual*]. The radio prompts you to enter the MMSI number you want to call. Enter the MMSI number the same way you enter directory entries (see page 15) Enter all nine digits and press **PUSH/ENTER**.
3. The radio prompts you to select a response channel. Turn the **PUSH/ENTER** knob to scroll through the available channels. When you reach the channel you want to use for a response, press **PUSH/ENTER**.
4. The radio displays the MMSI number you are about to call and asks you to confirm. If you want to call the displayed number, select *Send*. To cancel the call, select *Cancel*.
5. The radio automatically switches to channel 70 to transmit the call request.
  - When the other station accepts the call, both radios switch to the selected response channel for voice transmission.
  - If the other station cannot respond on the channel you selected, the radio displays *Not support CH*.

## Calling a particular group of stations (Group Call)

Group calling calls all the stations that share your group MMSI. You must have a group MMSI programmed into the radio to make a group call, and the stations you are calling must have this same group MMSI programmed into their radios.

1. Press **CALL-MENU** to open the call menu, and select *Group*.
2. The radio prompts you to select a response channel. Turn the **PUSH/ENTER** knob to scroll through the available channels. When you reach the channel you want to use for a response, press **PUSH/ENTER**.
3. The radio asks you to confirm the call. Select *Send* to continue with the call or select *Cancel* to cancel the call.
4. The radio switches to channel 70 to transmit the call request then automatically switches to the designated response channel.

## Calling all stations (All-Ships Call)

All ships calling contacts all DSC radios within range of your boat. You should only use all ships calling in the event of a Safety warning (such as debris in the water) or to request assistance in an Urgency (any situation where your vessel has a serious problem but is not yet in distress).

1. Open the call menu.
2. Select *All Ships*, and then choose whether this is an *Urgency* call or a *Safety* call.
3. The radio asks you to confirm the call. Select *Send* to continue with the call or select *Cancel* to cancel the call.
4. The radio automatically switches to channel 70 to transmit the call request then switches to channel 16 (the designated response channel for all-ships calling).

## Making an Automatic Distress Call

If you have programmed your MMSI number, your radio can transmit an automated distress call with your current location and nature of the distress. The radio then monitors the channel 16 for a response and repeats the distress call every few minutes until it receives an acknowledgement.

**To send an automatic distress call, press and hold DISTRESS for 3 seconds. If no MMSI number has been programmed, the radio prompts you to enter your MMSI number.**

If you want to include the nature of your distress in the distress call, use the following distress procedure:

1. Press **DISTRESS**. If no MMSI number has been programmed, the radio prompts you to enter your MMSI number.
2. The radio displays the list of distress conditions. Turn the **PUSH/ENTER** knob to select the nature of your distress.
  - Undesignated
  - Fire
  - Flooding
  - Collision
  - Grounding
  - Capsizing
  - Sinking
  - Adrift
  - Abandoning
  - Piracy/Armed
  - Overboard
3. Press and hold **DISTRESS** for 3 seconds.

## Canceling an automatic distress call

While the radio is waiting for a response, it gives you the option of canceling the call. To cancel the distress call, choose *Cancel* and press **PUSH/ENTER**.

## Receiving DSC Calls

If your radio receives an individual DSC call from another station, it sounds an incoming call tone and displays the name or MMSI number of the station calling.

- To respond to the call, select *Send: Able-Comply*; the radio sends an acknowledgement and automatically switches to the designated response channel. To reject the call, select *Send: Unable-Comply*; the radio advises the other station that you are unable to respond to the call.
- If the DSC request contains a response channel that you are not allowed to use, the radio displays *Not Support CH*; your only response option is *Send: Unable-Comply*.

- If the radio receives a group or all ships call, it sounds an incoming call tone and automatically switches to the designated response channel.
- If you disable automatic channel switching, the radio responds differently depending on the type of call it receives. If Auto CH SW is off and:
  - If the radio receives an incoming Distress, Group, or All Ships call, it displays the received call information but does not switch to the required channel.
  - If the radio receives an Individual call in the Distress/Urgency/Safety category, it switches to the required channel regardless of the AUTO CH SW setting. You can choose to reply or not. The radio displays *Send: Able-Cmply* and *Send: Unable-Cmply*.
  - If the radio receives an Individual call in the Routine category, it sends an *Unattended* message and does not switch channels.

## Reviewing the Receive Log

Just like your telephone's caller ID list, your radio keeps track of the calls you receive but do not answer. The receive log is useful if you have been off your boat or away from your radio and want to see who has tried to contact you. The radio displays the last 10 distress calls and the last 50 non-distress calls that it received. If you have unread incoming DSC calls, the radio displays a Message icon. When you display all *Distress* and *Other* receiving logs, the message icon disappears.

1. Press **CALL-MENU** to open the call menu.

2. Select *Receive Log*.

3. Select *Distress* to see the last 10 distress calls received by the radio. Select *Other* to see the last 50 normal calls received by the radio.

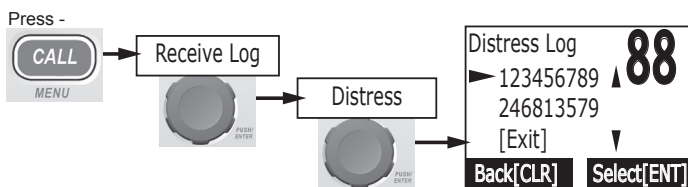

4. Calls are listed in the order they were received, with the newest call shown first. The display blinks if there are new calls you have not reviewed.

5. Select the call you want to see the details for. Turn the **PUSH/ENTER** knob to see all of the information.

- The log displays different information depending on type of call received. See the table below for the information stored for each type of call:

DSC Call Type	Receive Log Information
Distress	MMSI (or name), position, time, nature code.
Distress Acknowledge	MMSI (or name), distress MMSI, position, time, nature code.
Distress Relay	MMSI (or name), distress MMSI, position, time, nature code.
Distress Relay Acknowledge	MMSI (or name), distress MMSI, position, time, nature code.
Geographical	MMSI (or name), category code, communication channel number.
All Ships	MMSI (or name), category code, communication channel number.
Group	MMSI (or name), category code, communication channel number.
Individual	MMSI (or name), category code, communication channel number.
Individual Acknowledge	MMSI (or name), Completed/Unattended, category code, communication channel number.
Test	MMSI (or name), category code.
Test Acknowledge	MMSI (or name), category code.
Pos Reply	MMSI (or name), position, time, category code.
Pos Request	MMSI (or name), category code.
Pos Send	MMSI (or name), position, time, category code,

- Press **CLR** to exit the detail screen and return to the list of calls.
- Select *[Exit]* to close the receive log and return to the mode you were in.

## Returning a call

You can return individual calls directly from the receive log. From the call detail screen, turn the **PUSH/ENTER** knob clockwise until *Call Back* appears at the bottom of the display. Press **PUSH/ENTER** to return that station's call.

## Test Calls

### Making Test Calls (Test)

You can use the test call feature to make sure your radio is working and configured correctly. To avoid overloading coastal receiving stations, you should limit test calls to these stations to once a week.

 **NOTE:** Many coastal stations have specific frequencies and MMSI numbers you should use for making test calls. Before making a test call to a coastal station, be sure to check the Local Notice to Mariners (LNM), issued every week by the US Coast Guard. The LNM for each region are available online at <http://www.navcen.uscg.gov/Inm/default.htm>.

1. Press **CALL-MENU** to open the call menu.
2. Select *Test*.
3. The radio displays the names listed in your directory; turn the **PUSH/ENTER** knob to choose the directory entry you want to send a test call to and press **PUSH/ENTER**.
4. If you want to send a test call to a station that is not in your directory, select *[Manual]*. The radio prompts you to enter the MMSI number you want to call. Enter the MMSI number the same way you enter directory entries (see page 15). Enter all nine digits and press **PUSH/ENTER**.
5. The radio displays the MMSI number you are about to call and asks you to confirm. If you want to call the displayed number, select *Send*. To cancel the call, select *Cancel*.
6. The radio automatically switches to channel 70 to transmit the test call request, then switches back to the last-used channel.
7. When the other station acknowledges the test call, the radio displays an acknowledgement screen.

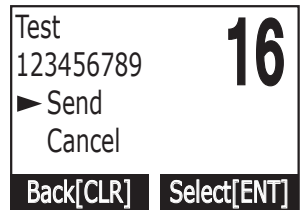
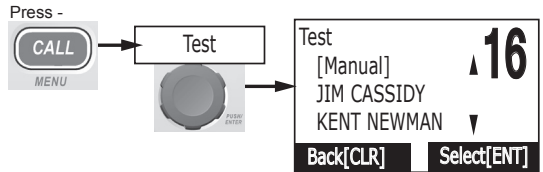

### Receiving Test Calls

When another station sends you a test call, the radio displays the test request screen.

- To acknowledge the test call, select *Reply*.
- To reject the test call, select *Cancel*.

### Enabling automatic test call reply

If you want the radio to automatically reply to all test calls, you can enable automatic test call reply.

1. Press and hold **CALL-MENU** to open the normal menu.
2. Select *Setup* and then *Test Reply*.
3. Choose *Auto* and press **PUSH/ENTER**.
4. To disable automatic test call reply, repeat the steps above and select *[Manual]*.

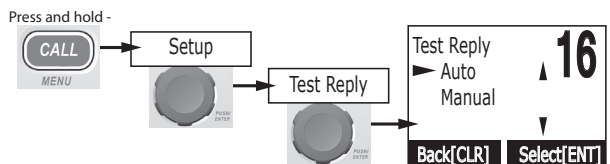

## Position Request and Reply

### Requesting another station's position (POS Request)

Anytime you need to know where another boat currently is—to find your boating partners, to respond to a request for assistance, etc.—you can send a position request to their radio:

1. Press **CALL-MENU** to open the call menu, then select *POS Request*.
2. The radio displays the names listed in your directory; turn the **PUSH/ENTER** knob to choose the entry you want to contact and press **PUSH/ENTER**.
  - If you want to contact a station that is not in your directory, select [*Manual*]. The radio prompts you to enter the MMSI number you want to call. Enter the MMSI number the same way you enter directory entries (see page 15). Enter all nine digits and press **PUSH/ENTER**.
3. The radio displays the MMSI number you are about to contact and asks you to confirm. If you want to request the position of the displayed MMSI number, select *Send*. To cancel the request, select *Cancel*.
  - When the other station responds, the radio displays the MMSI number, the longitude, and the latitude of the other station.
  - If your radio is connected to a chartplotter through the NMEA OUT connection (see page 26), the position information will also be displayed on the plotter screen.
  - If the other station does not have valid GPS data, the radio displays *No Position*.

## Receiving a position request (Position Reply)

When another station requests your current position, the radio displays the following screen:

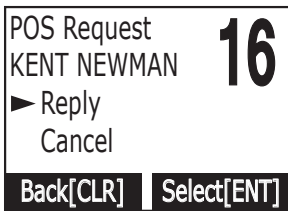

To send your current position to the other station, select *Reply*; the radio transmits your latitude and longitude to the other station. If you select *Reply* but the radio does not have valid GPS data, it transmits the reply code with *No Position*.

To reject the position request, select *Cancel*.

### Enabling automatic position reply

If you want the radio to automatically transmit your current position whenever it receives a position request, you can enable automatic position reply. Most boaters

activate automatic position reply for safety reasons or because they subscribe to a marine towing service. Sometimes—for example, in some competitive situations—you may not want other stations to get your position without your manual confirmation.

1. Press and hold **CALL-MENU** to open the normal menu.
2. Select *Setup* and then *POS Reply*.
3. Choose *Auto* and press **PUSH/ENTER**. The radio will automatically transmit your position when it receives a position request.
4. To disable automatic position reply, repeat the steps above and select [*Manual*].

## Sending your own position (Position Send)

If your radio is connected to a GPS receiver, you can send your boat's position to someone else. If you are requesting assistance or using an all ships call to give a safety warning, you can send your current position so other stations know where you are:

1. Press **CALL-MENU** to open the call menu.
2. Select *Position Send*.
3. The radio displays the names listed in your directory; turn the **PUSH/ENTER** knob to choose the entry you want to contact and press **PUSH/ENTER**.
  - If you want to contact a station that is not in your directory, select [*Manual*]. The radio prompts you to enter the MMSI number you want to call. Enter the MMSI number the same way you enter directory entries (see page 15). Enter all nine digits and press **PUSH/ENTER**.
4. The radio displays the MMSI number you are about to contact and asks you to confirm. If you want to transmit your position to the displayed MMSI number, select *Send*. To cancel the transmission, select *Cancel*.
  - The radio transmits your MMSI number, your longitude, and your latitude to the other station.



## Putting the Radio into Standby

If you are leaving your radio or do not wish to answer any DSC calls, you can put your radio in standby mode. If your radio receives an individual call, it will automatically respond with a message that indicates your radio is currently unattended. Follow the steps below to put your radio in standby:

1. Open the *Call* menu.
2. Select *Standby* to place your radio in standby mode. The radio displays the standby screen above.
3. To cancel standby and return to the mode your radio was in, press any button.

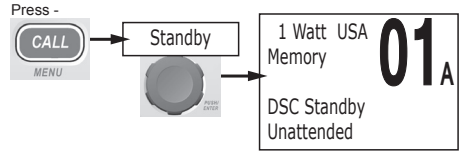

## Disabling Automatic Channel Switching

If you are involved in a bridge-to-bridge call, you may not want the radio to automatically switch channels when it receives a DSC call. In cases like this, you can disable automatic channel switching. If you receive an individual call, the radio will respond with an unattended code, just as if the radio were in Standby. See page 18 for more information about Automatic Channel Switching.

1. Press and hold **CALL-MENU** to open the normal menu.
2. Select *Setup* and then *Auto CH SW*.
3. Choose *Off* and press **PUSH/ENTER**. The radio displays the Auto channel Switch off icon and stops automatically switching channels until this feature is reactivated.

 **NOTE: Use this feature with caution. Deactivating automatic switching and then forgetting it can make it hard for you to receive DSC calls.**

If you have unread incoming DSC calls, the radio displays a message icon. You will be able to review who has called. The radio displays the last 10 distress calls and the last 50 non-distress calls it received (see the receive log on page 18).

## USING THE HAILER AND FOGHORN

### Connecting the Hailer/Foghorn Speaker

 **NOTE: These features require the installation of an optional hailer speaker. Contact your dealer for more information.**

Use the wiring diagram below to connect the included hailer cable to your optional speaker, then connect the cable to the hailer pigtail on the back of the radio.

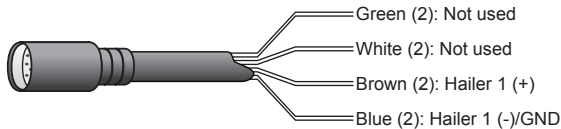

### Using the Hailer

- To activate hailing mode, press **HAIL-FOG**. The display shows *HA* in place of the channel number. (While in hailing mode, the radio will not transmit on any channel.)
- Press **PUSH-TO-TALK** to talk over the hailing speaker. You will also be able to hear yourself on the radio itself. When you release **PUSH-TO-TALK**, you can hear crewmembers speaking into the hailing speaker through the radio.
- To adjust the speaker volume, turn the **VOL** knob.
- To exit hailing mode, press **HAIL-FOG** again.

# Using the Foghorn

## Foghorn settings

You can set the vessel type, tone frequency, and default volume for the foghorn.

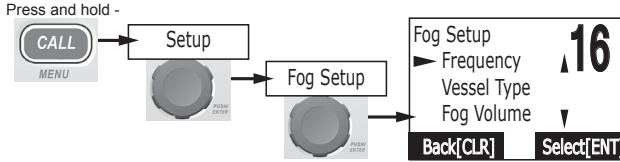

1. Open the normal menu and choose the *Setup* sub-menu.
2. Select *Fog Setup*, then choose one of the following options:

<i>Frequency</i>	To change the tone used by the foghorn for <i>Manual</i> , <i>Underway</i> , <i>Stop</i> , <i>Sail</i> , and <i>Tow</i> signals: <ol style="list-style-type: none"> <li>1. Turn the <b>PUSH/ENTER</b> knob to select a frequency between 200 Hz and 850 Hz in 50 Hz increments. Turn the knob clockwise to increase the frequency or counter-clockwise to decrease it.</li> <li>2. When you're satisfied with the frequency, press <b>PUSH/ENTER</b>.</li> <li>3. When the radio prompts to confirm, select <i>Yes</i>.</li> </ol>
<i>Vessel Type</i>	To make sure the fog horn uses the correct patterns for under way, under tow, and stopped signals, select whether your vessel is a <i>Motor</i> or a <i>Sail</i> vessel.
<i>Fog Volume</i>	To set the default volume for the foghorn, turn the <b>VOL</b> knob clockwise to increase the volume or counter-clockwise to decrease it. When you're satisfied with the volume, press <b>PUSH/ENTER</b> .

## Turning on the foghorn

1. Press and hold **HAIL-FOG** for about 2 seconds.
2. Turn the **PUSH/ENTER** knob to highlight one of the following foghorn signals.

Setting	Fog horn signal sounded	Horn sounds...
<i>At Underway</i>	<ul style="list-style-type: none"> <li>- If the GPS data indicates the vessel is moving, the horn sounds the <i>Underway</i> or <i>Sail</i> signal (based on the vessel type).</li> <li>- If the GPS data indicates the vessel is stationary, the horn sounds the <i>Stop</i> signal.</li> </ul>	every 2 minutes.
<i>At Undertow</i>	<ul style="list-style-type: none"> <li>- If the GPS data indicates the vessel is moving, the horn sounds the <i>Tow</i> signal.</li> <li>- If the GPS data indicates the vessel is stationary, the horn sounds the <i>Stop</i> signal.</li> </ul>	every 2 minutes.
<i>Manual</i>	Use of the Horn signal for passing.	when you press <b>PUSH-TO-TALK</b> .
<i>Underway</i>	Fog signal for a power boat that is underway.	every 2 minutes.
<i>Stop</i>	Fog signal for any vessel that is stationary (stopped).	every 2 minutes.
<i>Sail</i>	Fog signal for a sailboat, fish boat or towboat that is underway.	every 2 minutes.
<i>Tow</i>	Fog signal for any vessel under tow.	every 2 minutes.
<i>Anchor</i>	Fog signals for any vessel at anchor.	every minute.
<i>Aground</i>	Fog signals for any vessel aground.	every minute.
<i>Yelp</i>	Yelp type siren for Police, Fish & Game, US Coast Guard.	when you press <b>PUSH-TO-TALK</b> .

3. To activate the foghorn, press **PUSH/ENTER**. The radio exits the foghorn menu.
  - For *Anchor*, *Aground*, and *Yelp* signals, the radio sounds the foghorn using the standard, preset tone at the volume level chosen in the *Fog Setup* menu.

- For *Manual, Underway, Stop, Sail, and Tow* signals, the radio sounds the foghorn using the tone frequency and volume chosen in the *Fog Setup* menu.
- To turn off the foghorn, press **CLR**.

## INSTALLING THE HARDWARE

### Mounting the Radio

Your radio can sit at any angle in the mounting bracket so it can accommodate the best location. First, determine the best place to mount the radio. For optimum performance, find a location that can:

- Properly support the weight of the radio, approximately 2.2 pounds or 1.1 kilograms. You may need to use some type of anchor with the mounting screws to hold the radio, depending on the surface.
  - Keep the battery leads as short as possible.
  - Keep the antenna lead-in wire as short as possible.
  - Allow free air flow around the heat sink on the rear of the radio.
  - Avoid interference with the ship's compass.
1. Install the radio into the mounting bracket.
  2. Position the radio into the desired location. Mark the edges of the bracket on the mounting surface.
  3. Remove the mounting bracket drill template from the back of the manual, and use the template to mark the drill holes on the mounting surface.
  4. Drill the holes for the mounting bracket; be sure to follow any special requirements of the mounting surface.
  5. Remove the bracket from the radio, and use the mounting hardware to secure the bracket to the mounting surface.
  6. Install the radio back into the mounting bracket as shown.

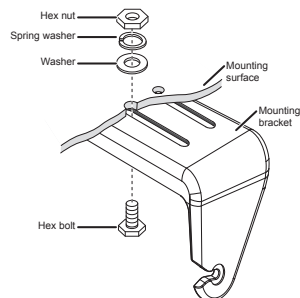

### Using the Flush Mount Bracket

#### Before you start

- Identify the hardware included with the flush-mount kit:



2 right angle brackets



2 flat brackets



4 stove bolts



2 lock washers



2 washers



2 slotted screws



4 lock nuts

- Use the proper template or the mounting height and width to cut the determine the size of the hole.
- Be sure there is enough depth behind your dash for the radio to fit and that you can reach behind the dash to attach the brackets and screws. (You'll have to do this from the back, so make sure your hands can fit in the space once the radio is already in place.)
- Be sure the power and antenna cables will reach once the radio is mounted.
- Be sure you use the recommended tools and follow all necessary safety precautions when cutting the hole in your dash (these will vary depending on the type of material, the thickness, etc.). Contact your boat's manufacturer or a professional installer if you aren't certain.

## Installing the radio

1. Cut the proper-sized hole in your dash.
2. Pass any cables through the hole, then insert the radio until the mounting flange is flush with the dash.
3. Use the screws and washers to attach the right angle brackets to the radio as shown.
4. Thread the lock nuts onto the stove bolts; turn them until they move up close to the bolt head.
5. Place the flat bracket against the dash and align the dimples with the holes in the right angle bracket.
6. Insert the bolts through the right angle bracket and into the dimples on the flat bracket, then tighten the bolts securely. Move the lock nuts down the bolts until they touch the bracket.
7. Use pliers or a wrench to tighten the lock nuts against the bracket.
8. Repeat this procedure with the other right angle bracket.

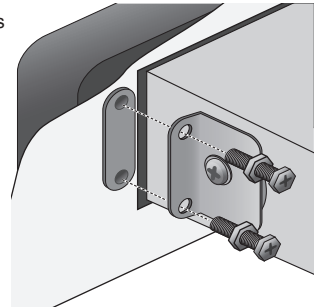
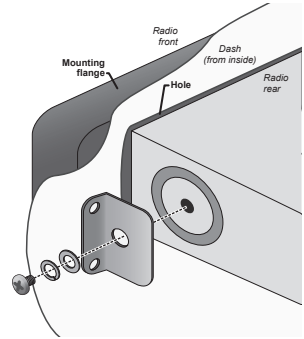

## Connecting the Radio

To operate correctly, your radio requires 2 electrical connections to:

- provide it with power from the boat's electrical system, and
- connect a VHF-FM marine antenna to the antenna connector.

Power Supply Requirements	VHF Antenna Requirements
<ul style="list-style-type: none"> <li>- Nominal 13.8 VDC power supply with a negative ground (10.4 VDC to 15.8 VDC).</li> <li>- Power leads should be kept as short as possible. A direct connection to the power supply is ideal.</li> <li>- Minimum of #14 AWG copper wire for extensions up to 20 feet, 12 AWG wire for extensions from 20 to 35 feet, or 10 AWG wire for extensions from 35 to 60 feet.</li> </ul>	<ul style="list-style-type: none"> <li>- Male PL-259 connector</li> <li>- 50 <math>\Omega</math> impedance</li> <li>- Minimum 4 foot, 3 dB rated antenna for sailboats or 8 foot, 6dB rated antenna for powerboats</li> <li>- Minimum RG-58 lead-in wire for antenna leads up to 20 feet, RG-8X for antenna leads from 20 to 35 feet, or RG-8U for antenna leads from 35 to 60 feet.</li> </ul>



**NOTE: To extend the life of the radio, use waterproof tape to seal electrical connections.**

1. Install your antenna according to the manufacturer's instructions.
2. Be sure there is enough distance between the antenna and any occupied areas.
  - The FCC recommends that antennas up to 3 dB be installed a minimum of 3 feet from any occupied location; antennas over 3 dB should be installed at least 6 feet away. If necessary, consult the FCC guidelines for antenna separation.
3. Connect the PL-259 connector from the antenna lead-in wires to the SO238 connector labeled **ANT** on the back of your radio.

## Connecting the Accessory Cable

Use the accessory cable to connect the radio to a GPS receiver, a GPS chartplotter, and an external speaker. The wiring diagram below shows the connections for each accessory:

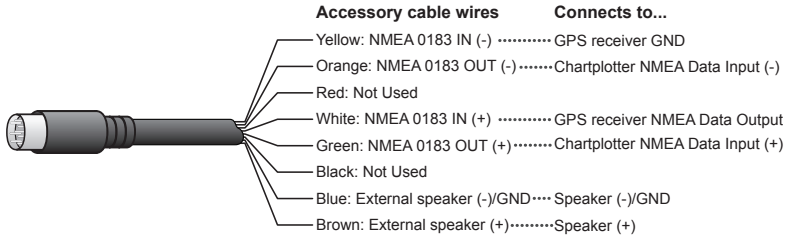

## Connecting to a GPS Receiver

If you connect the radio to a GPS receiver, the radio can automatically transmit your current position during an automated distress call or during a normal DSC call. The radio can also automatically set the time and date from the GPS receiver.

Your radio supports a standard NMEA0183 input from a GPS receiver. Below is a table of common GPS receivers and the proper connections:

GPS Manufacturer	Model Number(s)	GPS NMEA0183 OUTPUT Wire Color (connect to the accessory cable's WHITE wire)	Ground Wire Color (connect to the accessory cable's YELLOW wire)
Furuno	GP1650, GP1850	White	Black
Furuno	GP30, GP36	White	Blue
Garmin	Fixed Mount Models	Blue	Black
Garmin	Portable Models	Brown	Black
JRC	100 Series	Green	Black
JRC	200 Series	White	Black
JRC	GPS500	Yellow	Green
Lowrance / Eagle	Fixed Mount Models	White	Black
Lowrance / Eagle	Portable Models	Orange	Black
Magellan	Fixed Mount Models	Gray	Black
Magellan	Portable Models	Orange	Black
Northstar	All Models	Yellow	Black
Raymarine	420	Yellow	Brown
Raymarine	520 / 620	Blue	Brown
Raymarine	RL Series	White	Brown
Simrad	All Models	White	Brown
Sitex	Neptune, Nautilus	Gray	Brown
Standard	CP150 / CP150C	Green	Yellow

1. Connect the YELLOW wire of the included GPS cable to the GROUND wire on your GPS receiver.
2. Connect the WHITE wire of the included GPS cable to the GPS DATA OUTPUT wire on your GPS receiver.
3. Be certain all wire connections are secure and that all open wires are adequately covered.



**NOTE: To extend the life of the radio, use waterproof tape to seal electrical connections.**

4. Plug the GPS cable into the GPS pigtail on the back of your radio.

When the GPS receiver is correctly connected, the display shows *GPS Data OK*. Press **PUSH/ENTER** to open the GPS status screen and see detailed GPS data.

- If there is a problem with the GPS connection, the display shows *Check GPS*.
- If it does not receive coordinates from the GPS within 30 minutes from turning the power on, the radio sounds an alert and displays *Input Position*. This message remains until the radio receives coordinates, either automatically from the GPS or through manual input (see page 13).

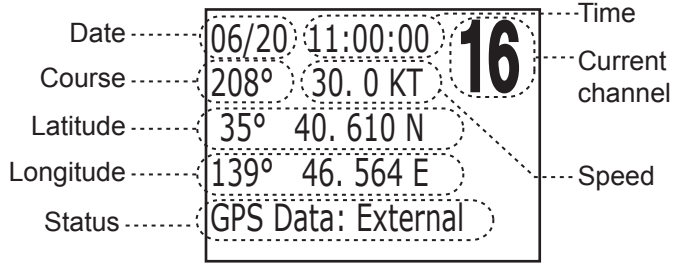

- If it goes 4 hours without receiving an update to the coordinates, the radio repeats the alert message once and prompts you to input your position again. During this time, *Input Position* remains on the screen and the radio uses the old coordinates for position replies and distress calls.
- If it goes 23.5 hours without receiving updated coordinates, the radio deletes the old coordinates and displays *Input Position*. Until it receives new coordinates, the radio sends *No Position Data* with position replies and distress calls.

## Configuring the GPS

If the radio is receiving valid GPS data, it will automatically set the clock to your local time based on the GPS location. You can adjust your local time forward or back 1 hour if necessary (for example, if you are close to the border of a time zone); you can also adjust for Daylight Savings Time.

1. Open the normal menu and choose the *Setup* sub-menu.
2. Select *GPS Setup* and then choose *Time Adjust*.
3. The display shows your current local time. Turn the **PUSH/ENTER** knob clockwise to adjust the time forward one hour; turn it counter-clockwise to adjust the time back one hour. Press **PUSH/ENTER** when you are finished.
4. When the radio prompts you to confirm, choose *Set* to save the new time or *Cancel* to exit without saving. The radio returns to the *GPS Setup* menu.
5. If your local area observes Daylight Savings Time, choose *Daylight Save* and press the **PUSH/ENTER** button.
6. If Daylight Savings Time is currently in effect, select *On*. If Daylight Savings Time is not currently in effect, select *Off*.
7. Press **PUSH/ENTER**. The radio activates the new time setting and returns to the *GPS Setup* menu.

## Connecting to a Chartplotter

Your radio provides a standard NMEA0183 GPS output that you can connect to a chartplotter. When it receives another boat's position data in a DSC call, the radio sends the position data to the chartplotter so you can see the location:

1. Connect the ORANGE wire of the accessory cable to the NEGATIVE (-) wire of your chartplotter's NMEA data INPUT.
2. Connect the GREEN wire of the accessory cable to the POSITIVE (+) wire of your chartplotter's NMEA data INPUT
3. Be certain all wire connections are secure and that all open wires are adequately covered.

 **NOTE: To extend the life of the radio, use waterproof tape to seal electrical connections.**

## Connecting to an External Speaker

You can use an external speaker to monitor the radio from a different part of your boat or in a noisy environment. If you turn the **PUSH/ENTER** knob on the radio, it will also adjust the external speaker volume.

Your radio supports an external speaker with the following specifications:

- Minimum impedance of 4 Ohms
  - Minimum power handling of 10 Watts
1. Connect the BLUE wire of the accessory cable to the GROUND wire of your external speaker.

2. Connect the BROWN wire of the accessory cable to the POSITIVE (+) wire of your external speaker.
3. Be certain all wire connections are secure and that all open wires are adequately covered.



**NOTE: To extend the life of the radio, use waterproof tape to seal electrical connections.**

## MAINTENANCE AND TROUBLESHOOTING

Due to its rugged design, your radio requires very little maintenance. However, it is a precision electronic instrument, so you should follow a few precautions:

- If the antenna has been damaged, you should not transmit except in the case of an emergency. A defective antenna may cause damage to your radio.
- You are responsible for continued FCC technical compliance of your radio.
- You should arrange for periodic performance checks with your dealer.

Problem	Things to Try
The radio won't power on.	<ul style="list-style-type: none"> <li>- Check the power connections.</li> <li>- Check the fuse.</li> <li>- Check the master battery switch and branch circuit that connect to the radio.</li> </ul>
Noise comes out of the speaker all the time	<ul style="list-style-type: none"> <li>- Adjust the squelch level; it is probably too low.</li> </ul>
I can't hear anything (no volume) from the speaker.	<ul style="list-style-type: none"> <li>- Adjust the squelch level; it is probably too high.</li> </ul>
The radio won't transmit.	<ul style="list-style-type: none"> <li>- Make sure you are not in weather or scan mode.</li> <li>- Make sure you are not trying to transmit on a receive-only channel (see the channels and frequency tables beginning on page 29).</li> <li>- Make sure you are transmitting at the correct power level for this channel (see the channels and frequency tables beginning on page 29).</li> <li>- Make sure the duration of each transmission is less than 5 minutes.</li> </ul>
I can transmit, but no one can hear me.	<ul style="list-style-type: none"> <li>- Check your UIC channel settings [see Setting the UIC Channel Mode (<i>USA/CAN/INT</i>) on page 5].</li> </ul>
The display flashes, and I don't know why.	<ul style="list-style-type: none"> <li>- The display will flash if the radio is in a watch mode or in scan mode. Try turning off scanning, Weather Alert Watch, or Triple/Dual Watch (see page 5.)</li> </ul>
I can't read the display.	<ul style="list-style-type: none"> <li>- Adjust the contrast and backlight brightness level (see page 12)</li> </ul>
The display is too bright at night.	<ul style="list-style-type: none"> <li>- Adjust the backlight brightness level (see page 12).</li> </ul>
I can't see any words on the display.	<ul style="list-style-type: none"> <li>- Reset the radio back to the default contrast level: turn off the radio; press and hold <b>CALL-MENU</b> while you turn it back on.</li> </ul>
I'm not getting any GPS data on my display	<ul style="list-style-type: none"> <li>- Make sure your GPS receiver is correctly connected (see Connecting to a GPS Receiver, page 25).</li> <li>- Make sure your GPS receiver is working properly.</li> <li>- Make sure that your GPS receiver supports the NMEA parameters described in NMEA Operation on page 25.</li> </ul>
I'm not getting any hazard alerts.	<ul style="list-style-type: none"> <li>- Make sure Weather Alert Watch is turned on.</li> <li>- Check to make sure the FIPS codes in your radio include your current location (see Using FIPS Codes for Weather Alerts on page 11).</li> </ul>
I'm getting all the hazard alerts, not just the ones for my area.	<ul style="list-style-type: none"> <li>- Check to make sure the FIPS codes in your radio were entered correctly (see Using FIPS Codes for Weather Alerts on page 11).</li> <li>- Sometimes the Weather Alert Watch may catch a hazard alert in the middle of the broadcast and miss which FIPS codes are affected. For your safety, the radio triggers the alert tone and switches to the weather channel when this happens.</li> </ul>
I can't make Group DSC calls.	<ul style="list-style-type: none"> <li>- Make sure the Group MMSI was entered correctly.</li> </ul>
Where can I find my radio's serial number?	<ul style="list-style-type: none"> <li>- Look on the right side of the radio (the side with the microphone cord), behind the mounting bracket.</li> </ul>
The radio won't let me enter my User MMSI. What do I do?	<ul style="list-style-type: none"> <li>- Contact customer service.</li> </ul>

## Performing a Self Test

The radio can check the electrical, hailer, and GPS connections.

1. Open the normal menu and choose the *System* sub-menu.
2. Select *Self Test*. The radio checks all connections and displays  where connections are good and an X beside an item that contained a problem.
3. Select the item with an X and press **PUSH/ENTER** for more detail.
  - *Hailer*: Not connected, Trouble
  - *GPS*: Not connected, NMEA sentences not supported
  - *Battery*: Too low or Too high (along with specific voltage)

## Engine Noise Suppression

Interference from the noise generated by the electrical systems of engines is sometimes a problem with radios. Your radio has been designed to be essentially impervious to ignition noise and alternator noise. However, in some installations it may be necessary to take measures to further reduce the effect of noise interference. Your radio's DC battery wires, antenna lead, and accessory cables should be routed away from the engine and engine compartment, and from power cabling carrying high currents. In severe cases of noise interference, it may be necessary to install a noise suppression kit. Contact the dealer where you purchased the radio for more information.

## SPECIFICATIONS

All specifications are subject to change without notice.

General	
Controls	<b>PUSH/ENTER, VOL</b> (volume), and <b>SQL</b> (squelch)
Status Indicators	Transmit power, Scan mode, Triple Watch mode, BATTERY HIGH, BATTERY LOW, USA, CAN, INT, Weather alert (ALT), Memory (MEM), GPS, Message, Weather band, GPS status, Channel display, Scramble (SCRM), UIC Area (USA Area, CAN Area, INT Area), Fog Horn (Auto Fog, Manual Fog, Underway Fog, Stop Fog, Sail Fog, Tow Fog, Anchor Fog, Aground Fog, Yelp Fog), and HAIL ERROR
Display	LCD (Full Dot Matrix)
Buttons	CALL-MENU, WX-MEM, CLR, 1W/25W/SCRAMBLER, HAIL/FOG, STEP/SCAN, 16/9-TRI, PWR, and DISTRESS
Connectors and Cables	Antenna, accessory, hailer, and DC power
Size	H 110 mm x W 165 mm x L 108 mm (without Heat Sink) H 4.33 inches x W 6.49 inches x L 4.25 inches
Weight	1.3 kg (2.9 pounds)
Supply Voltage	Nominal 13.8V DC, negative ground (10.4 VDC to 15.8 VDC)
Standard Accessories	Mounting bracket and hardware, microphone hanger and hardware, flush-mount kit, spare fuse
Antenna Impedance	50 Ω nominal
Microphone	Rugged 2 kΩ condenser mic element with coiled cord
Speaker	1.77 inch, 8 Ω
Operating Temperature Range	-20 °C to + 50 °C (-4 °F to +122 °F)
Shock and Vibration	Meets or exceeds EIA standards, RS152B and RS204C
FCC Approvals	Type accepted under part 80 of the Rules; meets Great Lakes Agreement and party boat requirements

Transmitter	
Power Output	1 Watt or 25 Watts (user selectable)
Power Requirement	25 watts output: 6A@13.8V DC
Modulation	±5 kHz deviation



Hum and Noise Signal-to-Noise	45 dB@1 kHz with 3 kHz deviation with 1000 Hz modulating frequency (nominal)
Audio Distortion	Less than 8% with 3 kHz deviation with 1000 Hz modulating frequency
Spurious Suppression	-25 dBm @ Hi, -25 dBm @ Lo
Output Power Stabilization	Built-in automatic level control (ALC)
Frequency Range	156 to 158 MHz
Frequency Stability	±10 ppm @ -20°C to + 50°C

Receiver	
Frequency Range	156 to 163 MHz
Sensitivity	0.25 µV for 12 dB SINAD (nominal)
Circuit	Dual Conversion Super Heterodyne PLL (Crystal for DSC)
Squelch Sensitivity	0.2 µV Threshold
Spurious Response	75 dB (nominal)
Adjacent Channel Selectivity	78 dB @ ±25 kHz (nominal)
Audio Output Power	1.5 watts (10% Distortion, 8 Ω load)
Power Requirement	340 mA @ 13.8V DC at squelched, 920 mA @ 13.8V DC at maximum audio output
IF Frequencies	1st 41.925 MHz, 2nd 455 kHz (1st 21.7 MHz, 2nd 455 kHz for DSC)

## REFERENCE TABLES

 This radio does not support AIS channels.

## Channel Descriptions and what They Mean

The table below lists the display name or channel description used in the following tables and what each description means.

Channel name/description	Used for:
DISTRESS SAFETY AND CALLING	primarily emergency messages and distress calls
INTERSHIP SAFETY	safety messages from one ship to another, or from a ship to Coast Guard aircraft
NON-COMMERCIAL (recreational or voluntary ships only)	messages about the needs of the ship, including fishing reports, rendezvous, scheduling repairs and berthing information
COMMERCIAL (working ships only)	messages about the needs of the ship or the business the ship is engaged in
PUBLIC CORRESPONDENCE/MARINE OPERATOR	calls to the marine operator at a public coast station. Marine operators can connect you to the telephone network so you can make and receive calls. (There is usually a charge for this service.)
PORT OPERATIONS/VTS (vessel traffic system)	messages about the movement and safety of ships in or near ports, locks or waterways. In certain major ports, some channels may be restricted to specific types of port operations messages.
NAVIGATIONAL/BRIDGE TO BRIDGE	messages about ship navigation, for example, passing or meeting other ships, maneuvering through locks, or navigating around drawbridges. Messages must be short!
STATE CONTROL	messages about government regulation and control, boating activities, or assistance to ships; also used to talk to ships and coast stations operated by state or local governments
DIGITAL SELECTIVE CALLING	DSC signals only (no voice communications allowed at any time)

## US Marine Channels and Frequencies

Ch No.	RX Freq	TX Freq	Status	Name on display
1A*	156.0500	156.0500	Simplex	Vessel traffic system/Commercial
5A	156.2500	156.2500	Simplex	Vessel traffic system/Commercial

Ch No.	RX Freq	TX Freq	Status	Name on display
6	156.3000	156.3000	Simplex	Inter-ship safety
7A	156.3500	156.3500	Simplex	Commercial
8	156.4000	156.4000	Simplex	Commercial
9	156.4500	156.4500	Simplex	Non commercial
10	156.5000	156.5000	Simplex	Commercial
11	156.5500	156.5500	Simplex	Vessel traffic system
12	156.6000	156.6000	Simplex	Vessel traffic system
13	156.6500	156.6500	Simplex, 1W	Bridge to bridge
14	156.7000	156.7000	Simplex	Vessel traffic system
15	156.7500	Inhibit	Receive Only	Environmental
16	156.8000	156.8000	Simplex	Distress, Safety, Calling
17	156.8500	156.8500	Simplex, 1W	Govt maritime control
18A	156.9000	156.9000	Simplex	Commercial
19A	156.9500	156.9500	Simplex	Commercial
20	161.6000	157.0000	Duplex	Port operation
20A	157.0000	157.0000	Simplex	Port operation
21A	157.0500	157.0500	Simplex	Coast guard only
22A	157.1000	157.1000	Simplex	Coast guard
23A	157.1500	157.1500	Simplex	Coast guard only
24	161.8000	157.2000	Duplex	Marine operator
25	161.8500	157.2500	Duplex	Marine operator
26	161.9000	157.3000	Duplex	Marine operator
27	161.9500	157.3500	Duplex	Marine operator
28	162.0000	157.4000	Duplex	Marine operator
63A	156.1750	156.1750	Simplex	Vessel traffic system
65A	156.2750	156.2750	Simplex	Port operation
66A	156.3250	156.3250	Simplex	Port operation
67	156.3750	156.3750	Simplex, 1W	Bridge to bridge
68	156.4250	156.4250	Simplex	Non commercial
69	156.4750	156.4750	Simplex	Non commercial
70	(156.5250	156.5250)	DSC Only	DSC
71	156.5750	156.5750	Simplex	Non commercial
72	156.6250	156.6250	Simplex	Non commercial (ship-ship)
73	156.6750	156.6750	Simplex	Port operation
74	156.7250	156.7250	Simplex	Port operation
75	156.775	156.7750	Simplex, 1W	Port operation
76	156.825	156.8250	Simplex, 1W	Port operation
77	156.8750	156.8750	Simplex, 1W	Port operation (ship-ship)
78A	156.9250	156.9250	Simplex	Non commercial
79A	156.9750	156.9750	Simplex	Commercial
80A	157.0250	157.0250	Simplex	Commercial
81A	157.0750	157.0750	Simplex	Government

Ch No.	RX Freq	TX Freq	Status	Name on display
82A	157.1250	157.1250	Simplex	Government
83A	157.1750	157.1750	Simplex	Coast guard
84	161.8250	157.2250	Duplex	Marine operator
85	161.8750	157.2750	Duplex	Marine operator
86	161.9250	157.3250	Duplex	Marine operator
87**	157.3750	157.3750	Simplex	Marine operator
88**	157.4250	157.4250	Simplex	Commercial (ship-ship)

\* A indicates simplex use of the ship station transmit side of an international duplex channel, and that operations are different from that of international operations on that channel.

\*\* Channels 87 & 88 revert from duplex to simplex operation. AIS channels are not supported.

### Canadian Marine Channels and Frequencies

Ch No.	RX Freq	TX Freq	Status	Name on display
1	160.6500	156.0500	Duplex	Marine operator
2	160.7000	156.1000	Duplex	Marine operator
3	160.7500	156.1500	Duplex	Marine operator
4A	156.2000	156.2000	Simplex	Canadian coast guard
5A	156.2500	156.2500	Simplex	Vessel traffic system
6	156.3000	156.3000	Simplex	Inter-ship safety
7A	156.3500	156.3500	Simplex	Commercial
8	156.4000	156.4000	Simplex	Commercial
9	156.4500	156.4500	Simplex	Boater calling channel
10	156.5000	156.5000	Simplex	Commercial
11	156.5500	156.5500	Simplex	Vessel traffic system
12	156.6000	156.6000	Simplex	Vessel traffic system
13	156.6500	156.6500	Simplex, 1W	Bridge to bridge
14	156.7000	156.7000	Simplex	Vessel traffic system
15	156.7500	156.7500	Simplex, 1W	Environmental
16	156.8000	156.8000	Simplex	Distress, Safety, Calling
17	156.8500	156.8500	Simplex, 1W	State control
18A	156.9000	156.9000	Simplex	Commercial
19A	156.9500	156.9500	Simplex	Canadian coast guard
20	161.6000	157.0000	Duplex, 1W	Port operation
21A	157.0500	157.0500	Simplex	Canadian coast guard
22A	157.1000	157.1000	Simplex	Canadian coast guard
23	161.7500	157.1500	Duplex	Marine operator
24	161.8000	157.2000	Duplex	Marine operator
25	161.8500	157.2500	Duplex	Marine operator
26	161.9000	157.3000	Duplex	Marine operator
27	161.9500	157.3500	Duplex	Marine operator
28	162.0000	157.4000	Duplex	Marine operator
60	160.6250	156.0250	Duplex	Marine operator
61A	156.0750	156.0750	Simplex	Canadian coast guard

Ch No.	RX Freq	TX Freq	Status	Name on display
62A	156.1250	156.1250	Simplex	Canadian coast guard
63A	156.1750	156.1750	Simplex	Port operation
64	160.8250	156.2250	Duplex	Marine operator
64A	156.2250	156.2250	Simplex	Port operation
65A	156.2750	156.2750	Simplex	Port operation
66A	156.3250	156.3250	Simplex, 1W	Port operation
67	156.3750	156.3750	Simplex	Bridge to bridge
68	156.4250	156.4250	Simplex	Non commercial
69	156.4750	156.4750	Simplex	Non commercial
70	(156.5250	156.5250)	DSC Only	DSC
71	156.5750	156.5750	Simplex	Non commercial
72	156.6250	156.6250	Simplex	Non commercial
73	156.6750	156.6750	Simplex	Port operation
74	156.7250	156.7250	Simplex	Port operation
75	156.7750	156.7750	Simplex, 1W	Port operation
76	156.8250	156.8250	Simplex, 1W	Port operation
77	156.8750	156.8750	Simplex, 1W	Port operation
78A	156.9250	156.9250	Simplex	Inter ship
79A	156.9750	156.9750	Simplex	Inter ship
80A	157.0250	157.0250	Simplex	Inter ship
81A	157.0750	157.0750	Simplex	Canadian coast guard
82A	157.1250	157.1250	Simplex	Canadian coast guard
83	161.7750	157.1750	Duplex	Canadian coast guard
83A	157.1750	157.1750	Simplex	Canadian coast guard
84	161.8250	157.2250	Duplex	Marine operator
85	161.8750	157.2750	Duplex	Marine operator
86	161.9250	157.3250	Duplex	Marine operator
87	157.3750	157.3750	Simplex	Port operation
88	157.4250	157.4250	Simplex	Port operation

### International Marine Channels and Frequencies

Ch No.	RX Freq	TX Freq	Status	Name on display
1	160.6500	156.0500	Duplex	Marine operator
2	160.7000	156.1000	Duplex	Marine operator
3	160.7500	156.1500	Duplex	Marine operator
4	160.8000	156.2000	Duplex	Marine operator
5	160.8500	156.2500	Duplex	Marine operator
6	156.3000	156.3000	Simplex	Inter-ship safety
7	160.9500	156.3500	Duplex	Marine operator
8	156.4000	156.4000	Simplex	Commercial (ship-ship)
9	156.4500	156.4500	Simplex	Boater calling channel
10	156.5000	156.5000	Simplex	Commercial

Ch No.	RX Freq	TX Freq	Status	Name on display
11	156.5500	156.5500	Simplex	Vessel traffic system
12	156.6000	156.6000	Simplex	Vessel traffic system
13	156.6500	156.6500	Simplex	Bridge to bridge
14	156.7000	156.7000	Simplex	Vessel traffic system
15	156.7500	156.7500	Simplex, 1W	Environmental
16	156.8000	156.8000	Simplex	Distress, Safety, Calling
17	156.8500	156.8500	Simplex, 1W	Govt maritime control
18	161.5000	156.9000	Duplex	Port operation
19	161.5500	156.9500	Duplex	Commercial
20	161.6000	157.0000	Duplex	Port operation
21	161.6500	157.0500	Duplex	Port operation
22	161.7000	157.1000	Duplex	Port operation
23	161.7500	157.1500	Duplex	Marine operator
24	161.8000	157.2000	Duplex	Marine operator
25	161.8500	157.2500	Duplex	Marine operator
26	161.9000	157.3000	Duplex	Marine operator
27	161.9500	157.3500	Duplex	Marine operator
28	162.0000	157.4000	Duplex	Marine operator
60	160.6250	156.0250	Duplex	Marine operator
61	160.6750	156.0750	Duplex	Marine operator
62	160.7250	156.1250	Duplex	Marine operator
63	160.7750	156.1750	Duplex	Marine operator
64	160.8250	156.2250	Duplex	Marine operator
65	160.8750	156.2750	Duplex	Marine operator
66	160.9250	156.3250	Duplex	Marine operator
67	156.3750	156.3750	Simplex	Bridge to bridge
68	156.4250	156.4250	Simplex	Non commercial
69	156.4750	156.4750	Simplex	Non commercial
70	(156.5250)	(156.5250)	DSC Only	DSC
71	156.5750	156.5750	Simplex	Non commercial
72	156.6250	156.6250	Simplex	Non commercial
73	156.6750	156.6750	Simplex	Port operation
74	156.7250	156.7250	Simplex	Port operation
75	156.7750	156.7750	Simplex, 1W	Port operation
76	156.8250	156.8250	Simplex, 1W	Port operation
77	156.8750	156.8750	Simplex	Port operation (ship-ship)
78	161.5250	156.9250	Duplex	Port operation
79	161.5750	156.9750	Duplex	Port operation

Ch No.	RX Freq	TX Freq	Status	Name on display
80	161.6250	157.0250	Duplex	Port operation
81	161.6750	157.0750	Duplex	Port operation
82	161.7250	157.1250	Duplex	Port operation
83	161.7750	157.1750	Duplex	Port operation
84	161.8250	157.2250	Duplex	Marine operator
85	161.8750	157.2750	Duplex	Marine operator
86	161.9250	157.3250	Duplex	Marine operator
87*	157.3750	157.3750	Simplex	Marine operator
88*	157.4250	157.4250	Simplex	Marine operator

\*Channels 87 & 88 revert from duplex to simplex operation. AIS channels are not supported.

## Weather Channels and Frequencies (US, CAN, and INT)

Ch No.	RX Freq	Name on display
WX01	162.5500	162.550 MHz
WX02	162.4000	162.400 MHz
WX03	162.4750	162.475 MHz
WX04	162.4250	162.425 MHz
WX05	162.4500	162.450 MHz
WX06	162.5000	162.500 MHz
WX07	162.5250	162.525 MHz
WX08	161.6500	161.650 MHz
WX09	161.7750	161.775 MHz
WX10	163.2750	163.275 MHz

- Status:RMC > GLL > GNS > GGA
- Latitude/Longitude:RMC > GLL > GNS > GGA
- UTC Time: RMC > GLL > GNS > GGA > ZDA
- Date: RMC > ZDA
- Speed / Course:RMC

 **NOTE 1: If the radio receives only a GLL sentence, the radio does not display the current speed, course, and date.**

 **NOTE 2: If the radio receives both RMC and GLL sentences, the radio uses only the RMC sentence.**

 **NOTE 3: Status data is used to check whether the GPS data is valid or invalid.**

## NMEA Output

When the radio receives a DSC call (Distress, Position Reply, or Position Send), it outputs a DSC/DSE sentence from the NMEA output port.

 **NOTE: When the radio receives a distress call, it outputs a sentence in the following format.**

- \$CDDSC,12,3081234000,,07,00,0354013946,0657,,S,E\*6D
- \$CDDSE,1,1,A,3081234000,00,60875646\*13

## NMEA Operation

This radio supports NMEA0183 version 3.01.

### NMEA Input

If you have difficulty getting your radio to receive data from your GPS receiver, check the device's configuration. It should be set to the following parameters:

Baud rate	4800 bps
Data bits	8
Parity	None
Stop bits	1
Data amplitude	Over 3.0 V
Drive capability	Over 10 mA

The radio supports RMC, GLL, GNS, GGA and ZDA sentences. When these sentences are received, the radio displays latitude/longitude, date, time, course, and speed. If any sentence except an RMC or GLL sentence is received, the radio uses the information based on the following priority order.

## Regulations and Safety Warnings

### Maritime radio services operation

**Warning!** This transmitter will operate on channels/frequencies that have restricted use in the United States. The channel assignments include frequencies assigned for exclusive use of the U.S. Coast Guard, use in Canada, and use in international waters. Operation on these frequencies without proper authorization is strictly forbidden. See the channel tables beginning on page 29 for a list of available channels and their uses. If you are still not certain which channels to use, see the FCC maritime radio page at the FCC website (<http://wireless.fcc.gov/marine/>) or contact the FCC Call Center at 1-888-CALLFCC. For individuals requiring a license, such as commercial users, you should obtain a license application from your nearest FCC field office (for US users) or Industry Canada (for Canadian users).

## Basic radio guidelines

You should familiarize yourself with the rules on marine radios and be aware of which rules apply to your boat. Complete guidelines for all ship and marine radio types can be found at the US Coast Guard website under the topic Radio Info for Boaters (the direct link is <http://www.navcen.uscg.gov/marcomms/boater.htm>). Here are a few guidelines that affect nearly all boaters.

- If you have a VHF radio on your boat, you must maintain a watch on channel 16 (156.800 MHz) whenever the radio is not being used to communicate. Effective from 2004, if a radio is carried, it must be turned on and set to channel 16 whenever your vessel is underway.
- If you hear a distress call, wait a few minutes to let a shore station or Coast Guard vessel respond. If no other station has responded after 5 minutes, you must respond to the distress call.
- Do not make false mayday or distress calls as a prank or to test your radio. (This is essentially like making a false 9-1-1 call; you may be subject to fines.)

## FCC Information

This device complies with Part 15 of the FCC Rules. Operation is subject to the condition that this device does not cause harmful interference.

Unauthorized changes or modifications to this equipment may void compliance with the FCC Rules. Any change or modification must be approved in writing by West Marine.

Any changes or modifications not expressly approved by the party responsible for compliance could void the user's authority to operate this device.

## Lead warning

The cords on this product and/or accessories contain lead, a chemical known to the State of California to cause birth defects or other reproductive harm. **Wash hands after handling.** West Marine works to reduce lead content in our PVC coated cords in our products and accessories.

## Antenna Selection and Installation

Your VHF680 has been designed to accommodate all of the popular marine VHF antennas. However, the selection and the installation of the antenna is the responsibility of the user or installer.

The FCC has determined that excessive radiation poses a health risk to people near radio transmitting antennas. Therefore, the antenna used with this radio should be installed using the following guidelines to ensure a suitable distance between the antenna and persons close by.

- Small whip antennas (3 dB) or smaller should be installed keeping at least a 2 foot separation distance between the radiating element and people.
- Medium antennas (6 dB) should be installed keeping at least a three foot separation distance.
- Larger antennas (9 dB) should be installed keeping at least a four foot separation distance.
- No person should touch the antenna or come into the separation distance when the radio is transmitting.

## Three Year Limited Warranty Statement

This Limited Warranty is Void outside the United States of America and Canada.

### What Does This Limited Warranty Cover?

West Marine warrants to the original retail purchaser of the West Marine product, where the purchase is made in the United States or Canada, that for thirty-six (36) months from date of original retail purchase said product will be free from defects in materials and craftsmanship with only the limitations or exclusions set out below.

### How Long Does This Limited Warranty Last?

This limited warranty is valid for thirty-six (36) months from the date of the original retail purchase from West Marine within the United States (the "Limited Warranty Term").

The warranty period is not extended if we repair or replace a warranted product or any parts. West Marine reserves the right to change the availability of limited warranties, at its discretion, but any changes will not be retroactive and will only apply to subsequent purchases.

### What Does This Limited Warranty Not Cover?

This limited warranty is invalid where and does not cover:

- Software.
- Commercial or industrial use or operation.
- Normal maintenance items or normal wear and tear.
- Problems resulting from fire or exposure to caustic liquids.
- The product was damaged, modified or altered.
- The product was used as part of any conversion kits, subassemblies, or any configurations not appropriate or contemplated for this product or its use.
- Damage or loss occurring during return shipment of the product to West Marine or its authorized service representative.
- The product was subject to improper service, repair, installation, storage, maintenance, alteration or application.
- Problems that result from accident, neglect, abuse, misuse or issues with electrical power,
- Problems caused by accessories, parts or components added to the product that are not appropriate for this product or its use.

**THIS WARRANTY GIVES YOU SPECIFIC LEGAL RIGHTS, AND YOU MAY ALSO HAVE OTHER RIGHTS WHICH VARY FROM STATE TO STATE (OR JURISDICTION TO JURISDICTION). WEST MARINE'S RESPONSIBILITY FOR MALFUNCTIONS AND DEFECTS IN HARDWARE IS LIMITED TO REPAIR OR REPLACEMENT AS SET FORTH IN THIS WARRANTY STATEMENT. ALL EXPRESS AND IMPLIED WARRANTIES FOR THE PRODUCT, INCLUDING BUT NOT LIMITED TO ANY IMPLIED WARRANTIES AND CONDITIONS OF MERCHANTABILITY AND FITNESS FOR A PARTICULAR PURPOSE, ARE LIMITED IN TIME TO THE TERM OF THIS LIMITED WARRANTY (AS SPECIFIED ABOVE). NO WARRANTIES, WHETHER EXPRESS OR IMPLIED, WILL APPLY AFTER THE LIMITED WARRANTY PERIOD HAS EXPIRED. SOME STATES DO NOT ALLOW LIMITATIONS ON HOW LONG AN IMPLIED WARRANTY LASTS, SO THE ABOVE LIMITATIONS MAY NOT APPLY TO YOU.**

**WE DO NOT ACCEPT LIABILITY BEYOND THE REMEDIES PROVIDED FOR IN THIS LIMITED WARRANTY OR FOR CONSEQUENTIAL OR INCIDENTAL DAMAGES, INCLUDING, WITHOUT LIMITATION, ANY LIABILITY FOR THIRD-PARTY CLAIMS AGAINST YOU FOR DAMAGES, FOR PRODUCTS NOT BEING AVAILABLE FOR USE, OR FOR LOST DATA OR LOST SOFTWARE. OUR LIABILITY WILL BE NO MORE THAN THE AMOUNT YOU PAID FOR THE PRODUCT THAT IS THE SUBJECT OF A CLAIM. THIS IS THE MAXIMUM AMOUNT FOR WHICH WE ARE RESPONSIBLE. SOME STATES DO NOT ALLOW THE EXCLUSION OR LIMITATION OF INCIDENTAL OR CONSEQUENTIAL DAMAGES, SO THE ABOVE LIMITATION OR EXCLUSION MAY NOT APPLY TO YOU.**

- If we repair or replace the product, we will return the repaired or replacement product to you; and
- Pay to ship the repaired or replacement product to you if you use an address in the United States (excluding Puerto Rico and U.S. possessions and territories). Otherwise, we will ship the product to you freight collect.

**If we determine that the problem is not covered under this warranty, we will notify you of this when we return your product to you to the address you provide us in the United States (excluding Puerto Rico and U.S. possessions and territories).**

**We use new and refurbished parts made by various manufacturers in performing warranty repairs and in building replacement parts and systems. Refurbished parts and systems are parts or systems that have been returned to West Marine, some of which were never used by a customer. Replacement parts and systems are covered for the remaining time left in the Limited Warranty Term for the product you bought (whatever time remains in the twelve months since purchase). West Marine owns all parts removed from repaired products.**

#### **What Must I Do To Keep the Warranty in Effect?**

- You must keep your receipt or other appropriate documentation as proof of the date of sale and purchase.
- You must keep your serial number or order number for the product. This is found on the product itself or on your receipt.
- You must not do any of the things that will make the warranty invalid as provided for in this warranty statement.
- You must use, install, maintain and operate the product in accordance with published specifications and the user's manual.

#### **What Do I Do If I Need Warranty Service?**

- Before the warranty expires, please call us at 1-800-BOATING (1-800-262-8464). Please also have your West Marine serial number or order number available.
- When you contact us, we will issue a Return Material Authorization Number for you to include with your return. We will also provide you the address of where to ship the product.
- You must return the product to us in its original or equivalent packaging, prepay shipping charges, and insure the shipment or accept the risk if the product is lost or damaged in shipment.

#### **What Will West Marine Do?**

During the Limited Warranty Term, if the product you return to us proves to be defective in materials or workmanship and not for the reasons which would otherwise disqualify it (as explained here), then we will:

- At West Marine's option, we will repair the product or, if we are unable to repair it, we will replace it with a comparable product that is new or refurbished;
- Or, as an alternative, at West Marine's option, we will refund you the original purchase price;

#### **Maintenance is the Owner's Responsibility**

Cleaning, polishing, lubricating, replacing filters, tuning, replacing worn parts, using your purchased product according to the user's manual, and regularly maintaining your purchased product is your responsibility.

#### **What if I purchased a Plus Protection Plan?**

Service will be provided to you under the terms of the Plus Protection Plan Contract. Please refer to that contract for details on how to obtain service.

#### **How State Law Relates to the Warranty.**

This warranty gives you specific legal rights, and you may also have other rights which vary from state to state.