 WARNING	<ul style="list-style-type: none"> ● CAREFULLY READ THIS MANUAL BEFORE OPERATING YOUR BOAT. ● THIS OWNER'S MANUAL IS IN TWO VOLUMES THAT MUST BE KEPT TOGETHER.
---	---

NOTICE:	<p>THE OWNER'S MANUAL IS IN TWO VOLUMES:</p> <ul style="list-style-type: none"> - VOLUME 1 DEALS WITH OPERATING PRECAUTIONS AND SAFETY RECOMMENDATIONS THAT MUST BE OBSERVED. - VOLUME 2 DEALS WITH TECHNICAL SPECIFICATIONS AND ASSEMBLY PROCEDURE OF THE BOAT AND ITS EQUIPMENT.
----------------	---

VOLUME 2
TECHNICAL SPECIFICATIONS - ASSEMBLY PROCEDURE

WEST MARINE
RU 3 - SB 4 - SB 5
HP 4 - HP 5
RIB 4 Light - RIB 5

CONTENTS



	Page		Page
⇒ Assembly procedure	3	⇒ Inflation	9
⇒ Check on unpacking	3	⇒ Pressure	10
⇒ Assembly	4-7	⇒ Assembly of equipment	11
⇒ Inflation system	8	⇒ Deflation - folding the boat	12
		⇒ General description	I - IV

RECOMMENDATIONS SIGNS



Throughout this manual there are advisories of safe operation.

The symbols below are advisories relative to various types of situations.

SECURITY SYMBOLS

 DANGER	DENOTES AN IMMANENT HAZARD WHICH WILL RESULT IN DEATH OR SEVERE INJURY IF NOT AVOIDED.
 WARNING	DENOTES A HAZARD WHICH COULD RESULT IN INJURY OR DEATH IF NOT AVOIDED.
 CAUTION	DENOTES A HAZARD OR UNSAFE PRACTICE WHICH COULD RESULT IN MINOR INJURY OR PRODUCT OR PROPERTY DAMAGE

GENERAL ADVISORY SYMBOLS

	THIS PROCEDURE OR BEHAVIOR COMPLIES WITH THE INSTRUCTIONS.
	THIS PROCEDURE OR BEHAVIOR DOES NOT COMPLY WITH THE INSTRUCTIONS THUS RISKING DAMAGE EQUIPMENT.
NOTICE :	GIVES IMPORTANT INSTRUCTIONS

This manual has been compiled to help you to operate your craft with safety and pleasure. It contains details of the craft, the equipment supplied or fitted, its systems, and information on its operation and maintenance. Read it carefully, and familiarize yourself with the craft before using it. Serious personal injury and death can occur in and around boats. **To prevent these tragic accidents, please read, understand and strictly enforce all safety rules.**

If this is your first craft, or you are changing to a type of craft you are not familiar with, for your own comforts and safety, please ensure that you obtain handling and operating experience before 'assuming command' of the craft. Your dealer or national sailing federation or yacht club will be pleased to advise you of local sea schools or competent instructors.

ASSEMBLY PROCEDURE

We recommend that you follow the specific order of the assembly procedure. Proceed step by step and refer to the corresponding pages.

PROCEDURE	PAGE	SECTION
1. inventory the elements composing your boat, and learn how to recognise them	3	CHECK ON UNPACKING
	I - IV	DESCRIPTION
2. activate valves in inflating position	8	INFLATION SYSTEM
3. slightly inflate the main buoyancy tube	9 - 10	INFLATION
4. RU 3 : Install the roll up floor SB 4 - SB 5 : assemble the floorboard HP 4 – HP 5 : inflate the floor	4 - 7	ASSEMBLY
6. finish inflation of the boat to the correct pressure	9 - 10	INFLATION / PRESSURE
7. Install the oars or the paddles.	11	ASSEMBLY OF EQUIPMENT

CHECK ON UNPACKING

 CAUTION	DO NOT USE A SHARP TOOL
---	--------------------------------

The pack must contain: 1 buoyancy tube +

 West Marine	RU 3	SB 4	SB 5	HP 4	HP 5	RIB 4 Light	RIB 5
Floor	RF (1)	MPF (2)	MPF (2)	HPIF (3)	HPIF (3)	GRPH (4)	GRPH (4)
Inflatable keel		1	1	1	1		
Stringers		2	2				
Repair kit	1	1	1	1	1	1	1
Owner's manual (5)	1	1	1	1	1	1	1

Standard equipment							
Inflatable thwart seat	1	1		1		1	
Pilot handles			2		2		2
Carry bag	1	1	1	1	1	1	
Telescopic aluminium oars	2	2		2		2	
Telescopic paddles			2		2		2
Standard Foot-pump	1	1	1			1	1
Hight pressure pump				1	1		

(1) RF: Roll-up floor (3) HPIF: High pressure inflatable floor (5) 2 volumes
 (2) MPF: Marine Plywood Floor (4) GRPH: GRP Rigid hull

You can equip your boat with many optional accessories (transportation wheels, boarding ladder, lifting rings etc.). Ask your dealer to advise you.

NOTICE :	IF YOU WISH TO ADD LIFTING RINGS, YOU MUST FIX THEM ON THE BUOYANCY TUBE, NEVER ON THE FLOOR
-----------------	---

ASSEMBLY

Choose a smooth and clean surface



IF THE BUOYANCY TUBE WAS STORED AT A TEMPERATURE BELOW 0°C / 32°F, LEAVE IT AT 20°C / 68°F FOR 12 HOURS BEFORE UNFOLDING.

RIB 4 LIGHT - RIB 5

No assembly is required

HP 4 - HP 5 : INFLATE THE HIGHT PRESSURE FLOOR

HP INFLATABLE FLOOR DEFLATED

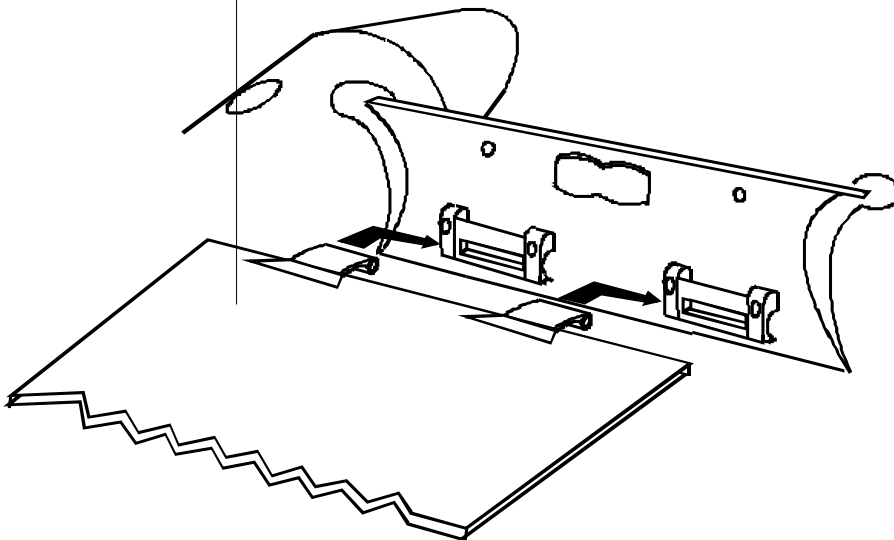

ASSEMBLY

RU 3: INSTALL THE ROLL-UP FLOOR

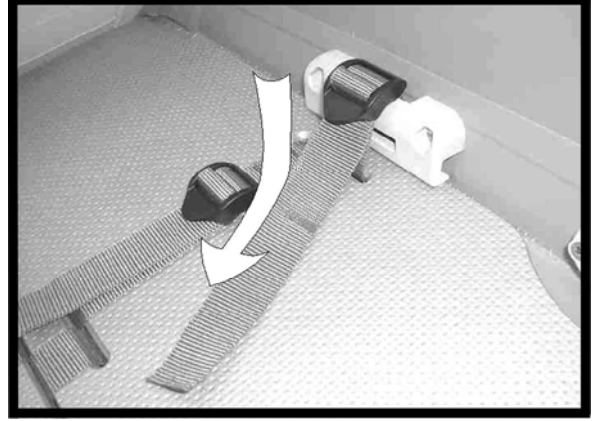
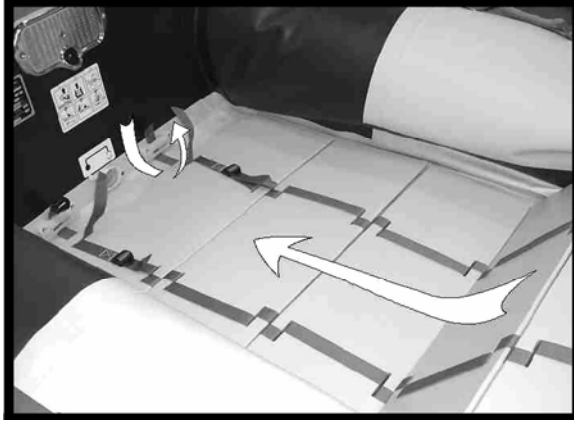

ASSEMBLY

SB 4 - SB 5 : INSTALL THE MARINE PLYWOOD FLOOR :

- Sprinkle some starch in the angle (joint of the buoyancy tubes to the bottom) to facilitate fitting.
CAUTION, NEVER USE TALCUM POWDER.

- **Make sure you identify the parts and direction in which they fit:**

The floorboard consists of 3 main sections and 1 or 2 sections in the bow [fig 1 and 4].

The boards are identified by a number (1, 2, 3) from the bow.

1. Insert the bow section (1) into the bow angle.
2. Insert the rear section (5) against the transom (6) as show on fig 1.
3. Fit all sections together [fig.1].
4. Position sections 3 and 4 as an apex (in a tent-like position) [fig 1 and 2].
5. Check that all sections are correctly aligned [fig 4].
6. Check that the floorboard is correctly fitted in the angles.
7. Flatten the apex by standing on it (in the boat) and pulling the lifelines to prevent the fabric being pinched [fig. 2].
8. Assemble the stringers (see instructions bellow).

ASSEMBLY OF THE STRINGERS

The stringers are essential to good working of the boat: they lock the floorboard together and rigidify its structure.

1. To facilitate the fitting of the first stringer, slide the other stringer under the boat, about 8" from the side [fig. 3-a].



DO NOT PUT THE STRINGER IN POSITION UNDER THE BOAT UNTIL THE FLOOR IS FLATTENED.

2. Position the stringer on the edge of the floorboard. The reference mark on the stringer (8) must remain on top (**the thicker part should be towards the top**) [fig. 3].
3. Fit the stringers between the two buffers (9) of sections 3 and 5 [fig. 4].
4. Rotate the stringer in the angle so as to press them against the bottom [fig. 3-b and 4].
5. Because of the self-locking system of the floorboard, the stringers will fit into place once the buoyancy tube is inflated.

ASSEMBLY (MARINE PLYWOOD FLOOR)

fig 1-A

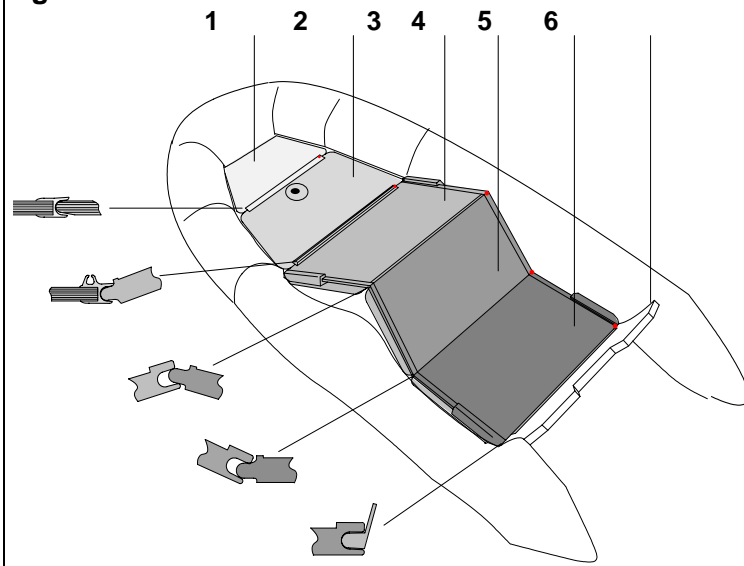

fig 1-B

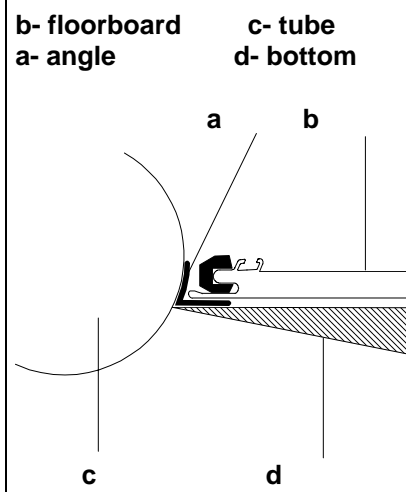

fig 2

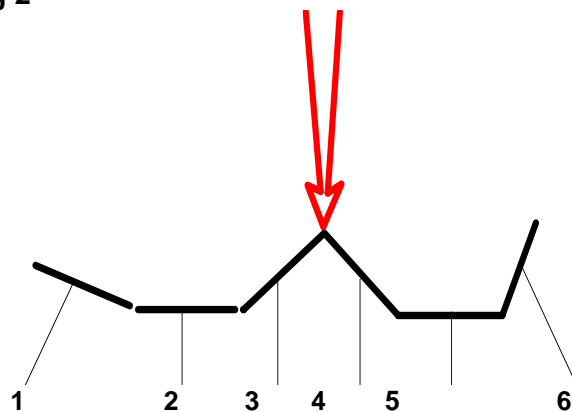
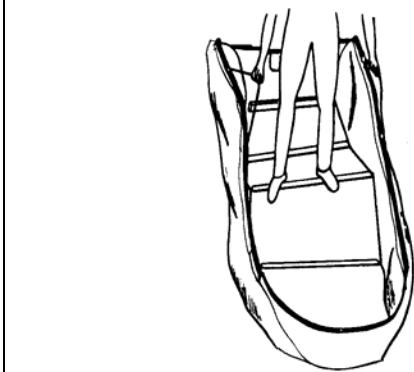

fig 3

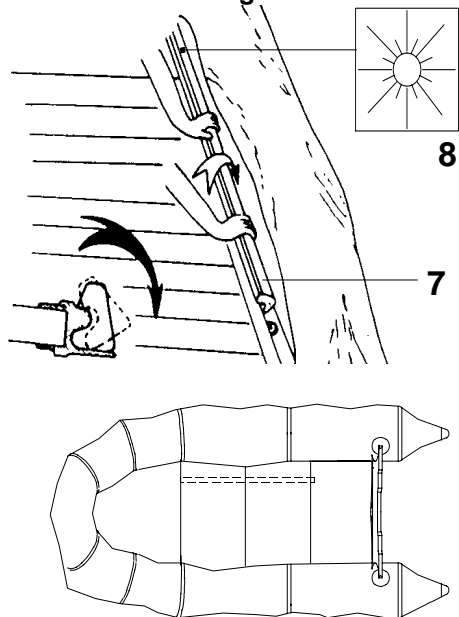
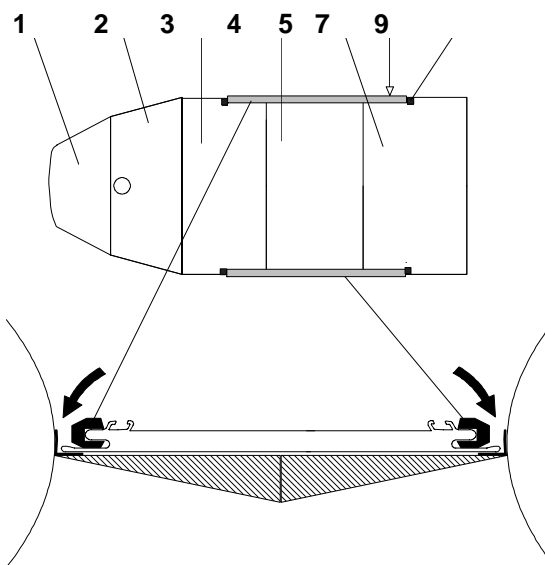

fig 4



INFLATION SYSTEM

The inflation system is composed of:

THE FOOT PUMP

- a. connecting tip
- b. hose end piece
- c. hose base
- d. outlet for inflation

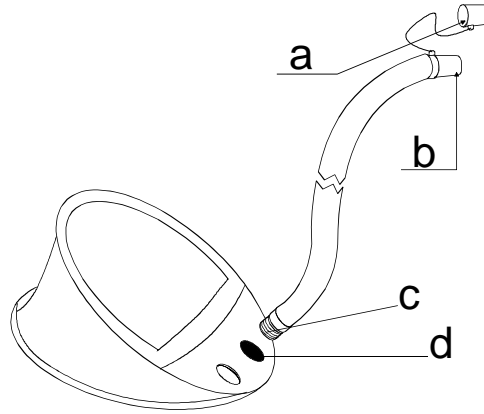

THE STANDARD VALVES

TO ACTIVATE THE VALVES INTO INFLATION POSITION:

- Free the valve insert from its protection.
- Unscrew the valve cap.
- Screw the valve support onto its base (screw it tight but without exaggeration, not to deteriorate the screw thread) and check that the valve cap stays accessible.

- (1) CAP
- (2) VALVE INSERT
- (3) BASE

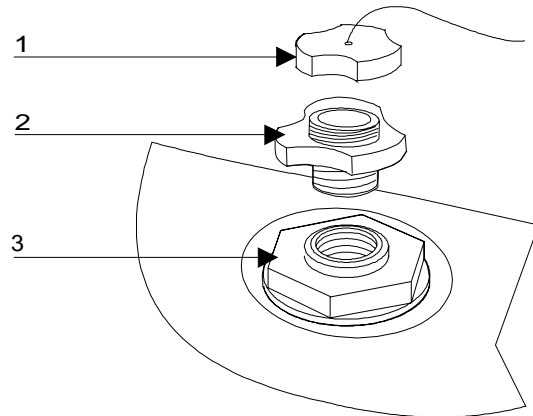

TO DEFLATE:

Unscrew the valve support from its base

THE SEMI-RECESSED VALVES

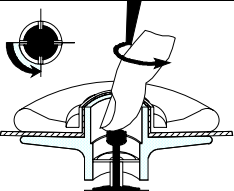
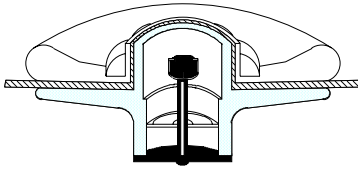
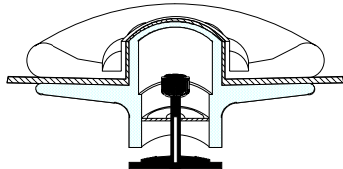
To activate the valves:	Inflation position	Deflation position
 <p style="text-align: center; margin-top: 5px;">press the push-in stem a quarter of a turn</p>	 <p style="text-align: center; margin-top: 5px;">diaphragm closed, the inner button springs upwards</p>	 <p style="text-align: center; margin-top: 5px;">diaphragm open, the inner button goes down</p>

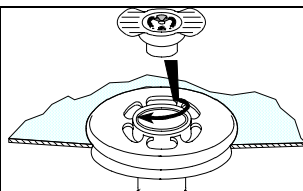
NOTICE:	<p style="text-align: center; margin: 0;">TO SCREW OR UNSCREW THE VALVE CAPS, TURN WITHOUT PRESSING OR FORCING (THIS COULD UNSCREW THE INNER VALVE SYSTEM).</p>	
----------------	--	---

INFLATION

Activate all valves into inflation position.

Fit the hose to the foot-pump.
To inflate your boat properly, the bottom side of the foot-pump must rest on a flat ground.
Pump evenly to inflate rapidly.

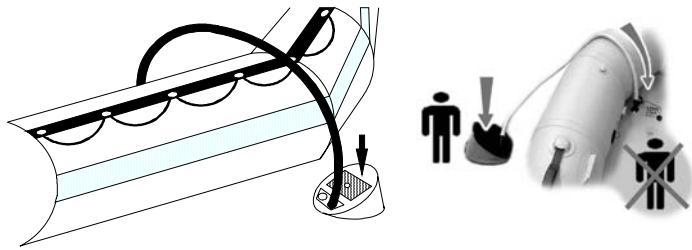

 WARNING	DO NOT USE A COMPRESSOR OR A BOTTLE OF COMPRESSED AIR
--------------------	--

You can use the electrical air pump *ACCESS* (ask your Dealer).

A - INFLATE THE H2P FLOOR (MODELS HP ONLY)

- Insert the pump hose end piece.
- Inflate.

B - INFLATE THE MAIN BUOYANCY TUBE

- Insert the pump hose end piece
- Inflate (**pressure = 240 mbars – 3.4 PSI, reffer to PRESSURE section**) making sure that each compartment is equal. When correctly inflated, the internal bulkheads (a) are not visible.

 WARNING	NEVER INFLATE THE MAIN BUOYANCY TUBE OR THE KEEL AT A PRESSURE HIGHTER THAN 240 MILLI BARS (3.4 PSI.) <u>THERE WOULD BE A RISK OF BURST.</u>
--------------------	--

	NEVER COMPLETELY INFLATE A COMPARTMENT TO FULL PRESSURE IF OTHER COMPARTMENTS ARE TOTALLY DEFLATED	
--	---	--

	1	
--	----------	--

	2	
--	----------	--

C - INFLATE THE KEEL (SB 4 - SB 5 ONLY)

pressure = 240 mbars – 3.4 PSI

Inflation is over: fit the valve caps tight (clockwise).

NOTICE :	A slight air-leak before screwing the valve caps is normal. ONLY THE VALVE CAPS CAN ENSURE FINAL AIR TIGHTNESS.
-----------------	---

PRESSURE

The correct pressure for the buoyancy tube and the keel is 240 mb/3,4 PSI, and 800 mb / 11,3 PSI for the HP inflatable floor (models HP and Speedster only).

If your boat is not equipped with a **ACCESS** pressure indicator, we recommend that you purchase one from your Dealer. This will permit a quick and efficient control of the pressure during inflation. Without a pressure indicator, stop inflating when the foot-pump gets difficult to operate, and the boat is « hard » (you should not be able to bend the cone ends).

Ambient temperature of air and water have an effect on the boat's internal pressure

Ambient temperature	tubes' internal pressure
+1°C / +1,8°F	+4 mb / 0,06 PSI
-1°C / -1,8°F	-4 mb / 0,06 PSI

Therefore, it is important to anticipate:

Because of temperature variations (especially when this variation is important between the beginning and the end of the day, in hot areas) check and adjust the pressure in the inflated compartments by inflating or deflating. Be sure that pressure remains within the recommended zone, between 220 mb/3,10 PSI and 270 mb/3,85 PSI (green area).

RISK OF UNDERPRESSURE

EXAMPLE: Your boat is in direct sunlight on the beach (temperature =50°C/122°F) at recommended pressure (240 mb/3,4 PSI). After putting it in the colder water (temperature =20°C/68°F), the internal temperature and pressure of the tubes will both drop (up to 120 mb/1,7 PSI) and **YOU WILL HAVE TO INFLATE AGAIN** until you regain the lost pressure due to the difference in temperatures. Therefore, a loss of pressure at the end of the day when ambient temperature drops is perfectly normal.

NOTICE :

Proper inflation is critical to the performance of the boat. It is the pressure in the tubes that gives your boat the necessary rigidity to perform well. Under-inflation causes improper flexing of the tubes which will result in stress and chafe

RISK OF OVERPRESSURE

EXAMPLE: Your boat is inflated to the recommended pressure (240 mb/3,4 PSI) at the beginning of the day (low ambient temperature =10°C/50°F). Later in the day, your boat is in direct sunlight on the beach or on a yacht's deck (temperature =50°C/122°F). Internal temperature of all inflated compartments can then increase and reach up to 70°C/158°F (especially for dark-coloured tubes). The consequence will be a doubling of previous pressure (480 mb/6.8 PSI). **YOU WILL THEN HAVE TO DEFLATE** until you reach the recommended pressure.



WARNING

WHEN YOUR BOAT IS OVER INFLATED, PRESSURE BECOMES TOO STRONG FOR THE INFLATABLE STRUCTURE, AND COULD CAUSE A BREAK IN THE FABRIC ASSEMBLY

IN CASE OF OVERPRESSURE

STANDARD VALVE (A):

Free some air by pushing on the diaphragm (1) with a blunt object.

Beware not to fold down the diaphragm.

SEMI-RECESSED VALVE (B):

deflate by pressing the spring loaded button.

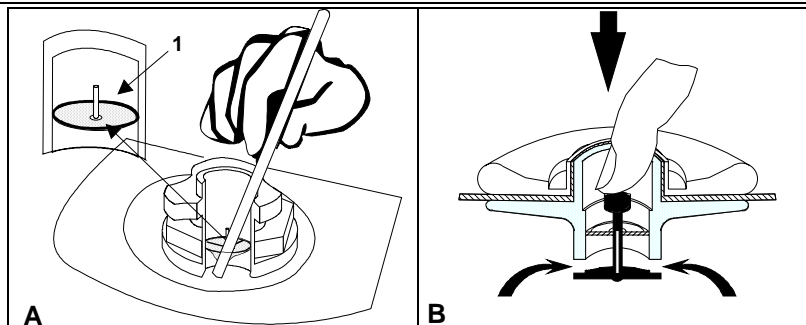

ASSEMBLY OF STANDARD EQUIPMENT

TO ASSEMBLE AND INSTALL THE OARS OR THE PADDLES

TELESCOPIC OARS

- 1. oar blade
- 2. oar handle
- 3. oarlock

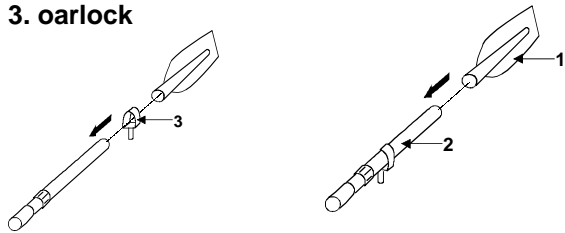

To assemble the oars, insert the oar handle into the oarlock, and the oar handle into the blade and turn until the safety catch is on.

To insert in the oar support

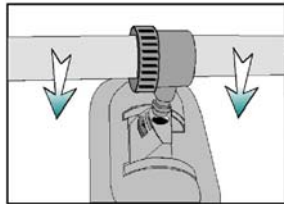

To remove from the oar support

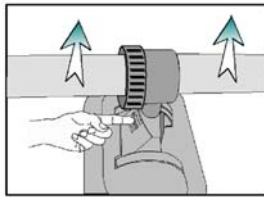

TELESCOPIC PADDLES

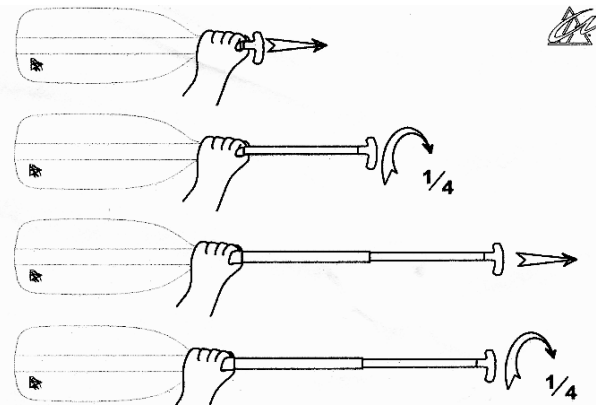

THE TRIM TAB BRACKETS (OPTIONAL). (PREPARED ONLY ON SB AND HP MODELS).

Your boat has been prepared to allow the installation of a flap kit that significantly improves navigation. This kit reduces nose up and improves planing. You can obtain it from your dealer.

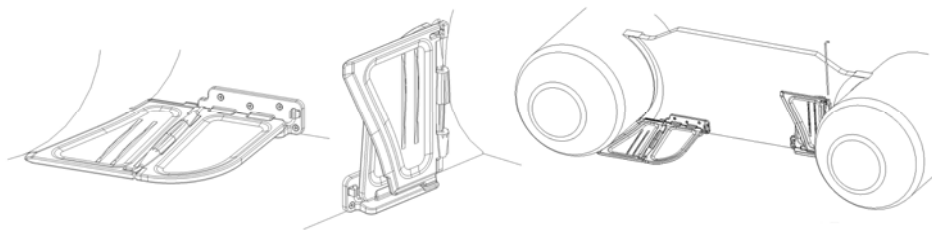

DEFLATING / FOLDING THE BOAT

1. **Deflate** the boat.
2. **Replace** the valve protections.
3. **Remove** oars and equipment.
4. **Remove** the floorboard (for boats with a roll-up floor or an inflatable floor, It is not necessary to remove the floor to fold the boat).
5. **Empty** the boat of all water and sand by opening the self-bailers, dry it.
6. **Fold in** the 2 sides of the main buoyancy tube (A), fold the cones onto the transom, then **roll up** the boat around the transom (C). Start again if you feel there is still some air left in the tubes.

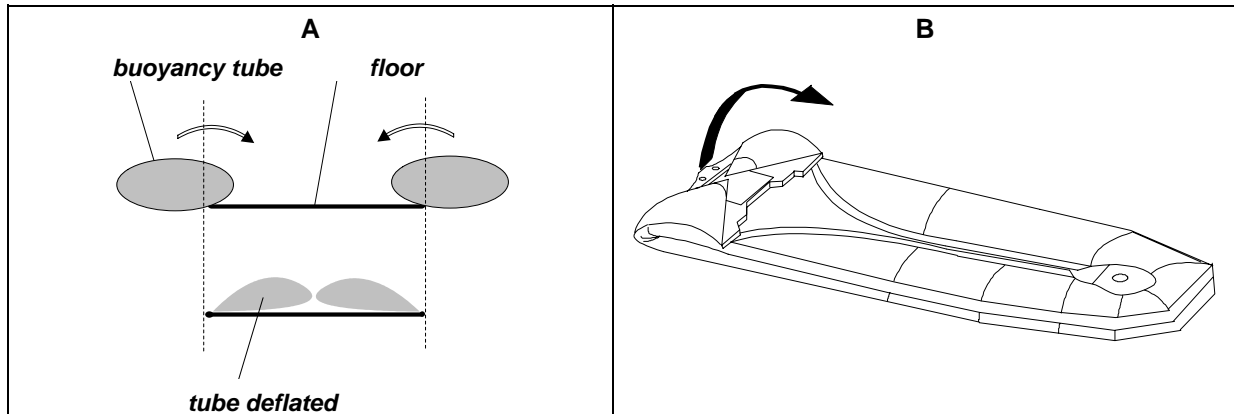

FOR MODELS WITH FINS UNDER THE FLOOR:

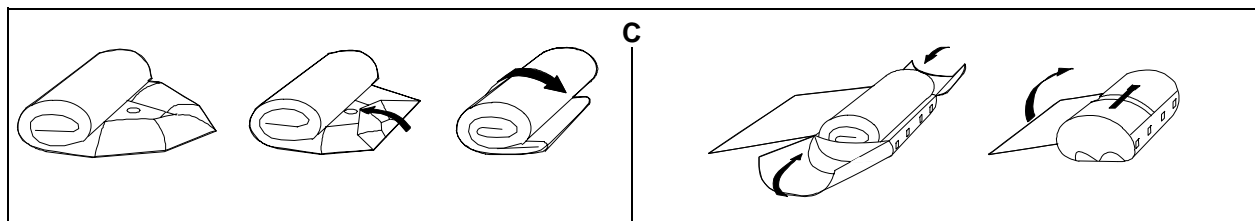
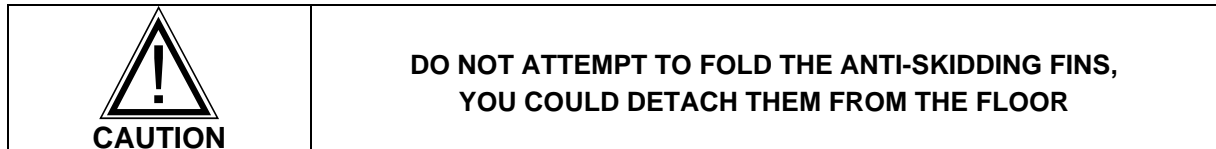
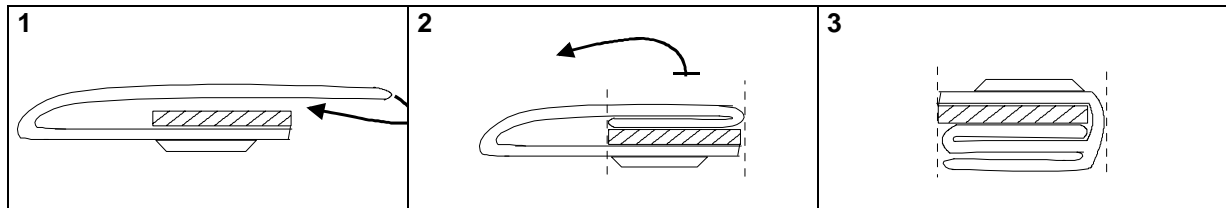

Stow the boat in its bag (in its cover for the RIB Light).

MAINTENANCE / DISMANTLE OF THE H2P INFLATABLE FLOOR. (HP MODELS ONLY)

We recommend that you leave the H2P floor in the boat when folding.
However, to clean perfectly the boat it may be useful to take off the H2P floor:

DISMANTLE: Deflate the boat and take off the H2P floor

MAINTENANCE: inflate again the boat

Wash off with clear water, then raise the boat's nose to evacuate water and sand or rubbish.