

General Info ::

- :: Always flush prior to use.
- :: Protect from freezing.
- :: Store in refrigerator or other cool place, out of direct sunlight.
- :: **CAUTION:**
Do not use where water is microbiologically unsafe or of unknown quality without adequate disinfection before or after filtration.
- :: Never expose to more than 125 PSI. Always use a Water Pressure Regulator upstream of filter.
- :: Use supply hoses that are suitable for drinking water.
- :: To ensure the best quality water at all times and to maximize the convenience of your experience, it is recommended that a spare cartridge (West Marine's Replacement Filter Cartridge Model 13915145) be kept in a safe place in your vessel to be used in the event of severely adverse water conditions.

Premium Water Filter Kit Instructions

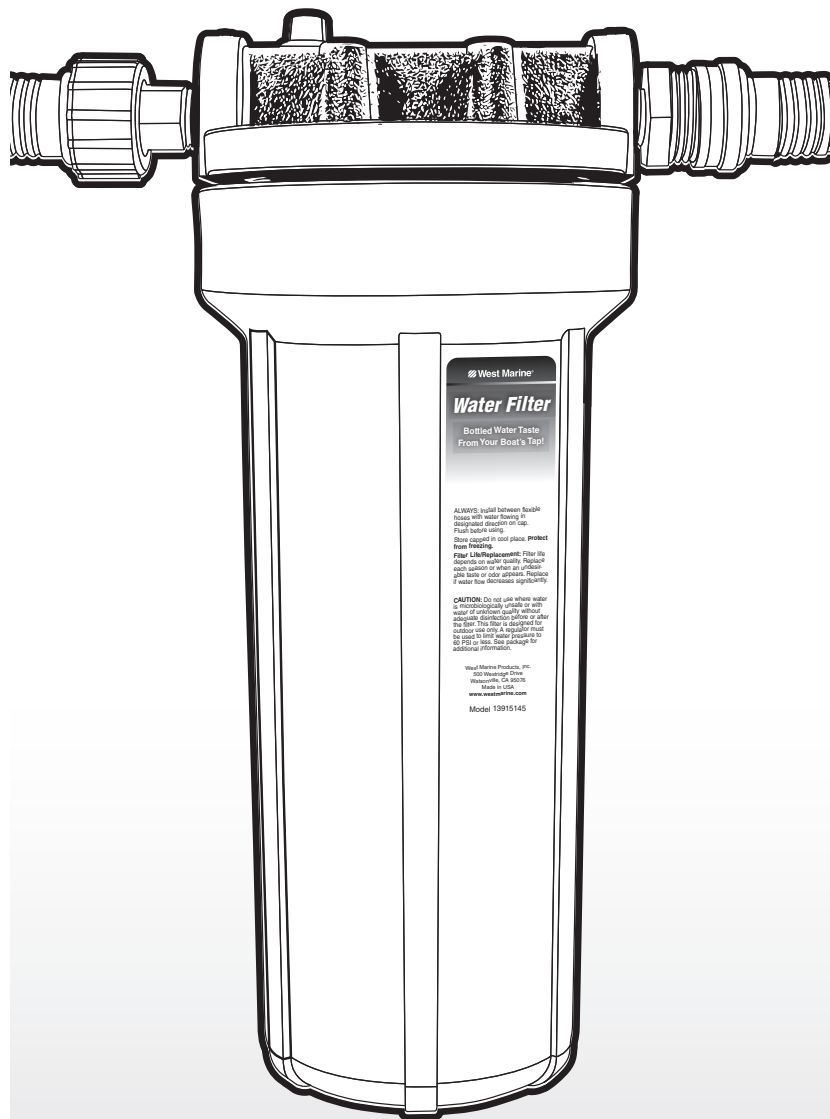

West Marine Products, Inc.
500 Westridge Drive, Watsonville, CA 95076
Made in USA
www.westmarine.com

Bottled Water Taste From Your Boat's Tap!

*

- **Universal—Fits Cartridges:**
9-3/4 inches to 10 inches Tall – 2-1/2 inches to 3 inches diameter

First — Filter Cap Installation ::

A ::

Apply 5 to 7 wraps of Teflon tape (clockwise) to the male pipe threads of the Male and Female Hose Fittings as shown. Install the Female Hose Fittings into the cap port marked "IN." Install the Male Hose Fittings into the cap port marked "OUT." Tighten each fitting using a wrench leaving one thread visible. Leak test. If fittings leak, tighten 1/2 turn and leak test again. DO NOT OVERTIGHTEN.

B ::

Check that Housing Cap is securely tightened. Tighten with minimal force using provided wrench if necessary. DO NOT OVERTIGHTEN.

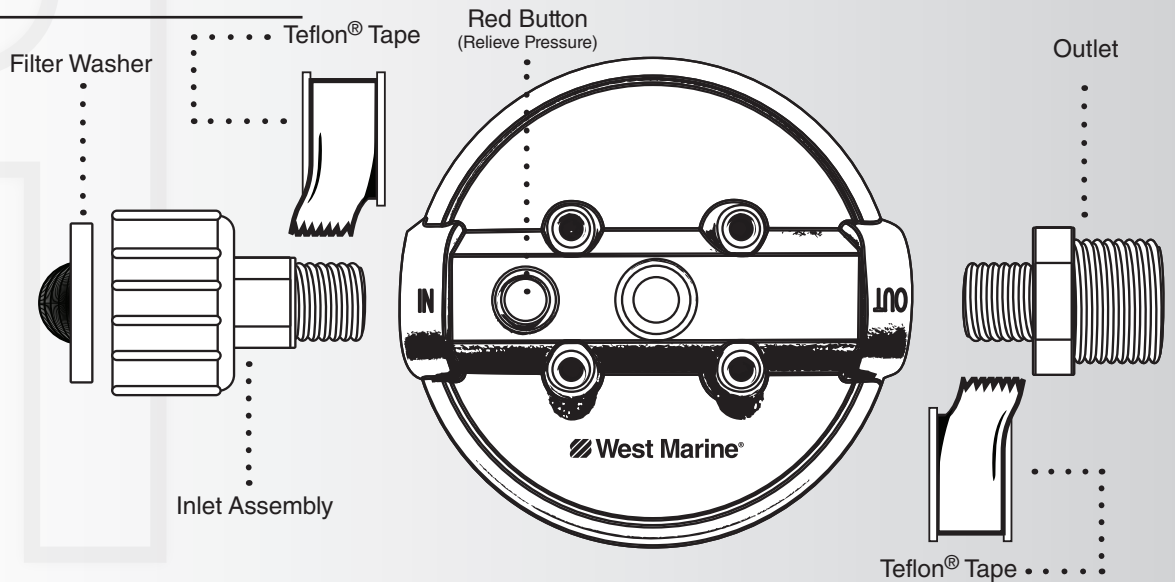

Second — Hook-up Installation ::

Filter can be installed close to the boat's water inlet or near the water source. It is recommended to install filter as close to the water inlet as possible. **Note: To prevent breakage, do not connect filter directly to water pressure regulator, faucet, or boat.**

A ::

Attach incoming water supply (hose) to female fitting at "IN" port of filter.

Turn on water and flush for two minutes prior to first connection to boat.

Turn water off.

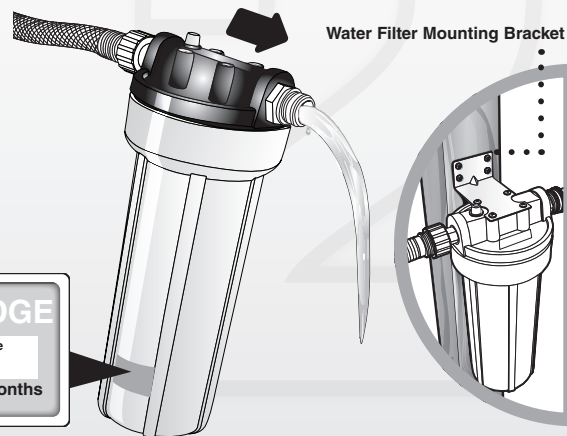

B ::

- Attach supplied connector hose to boat's water inlet. Attach filter and water source hose.

- Or attach supplied connector hose to faucet. Attach filter and water inlet hose.

• • • • • Boat Installation

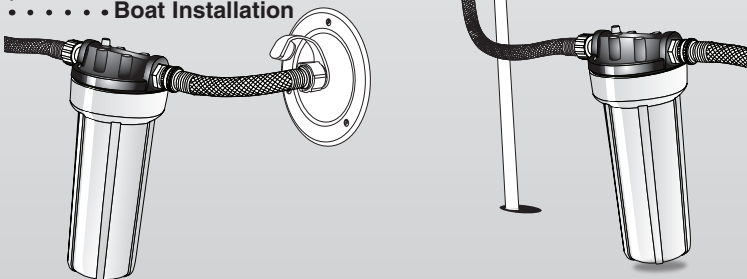

Cartridge Replacement ::



1. Turn off water source and press the Red Button to relieve pressure.
2. Unscrew Filter Casing Cap (Using provided wrench if necessary), remove and discard used cartridge.
3. Rinse out Filter Casing and Cap. Scrub using a non-abrasive sponge and mild soap if necessary.
4. Carefully remove O-ring in Canister and wipe both ring and groove clean. Lubricate O-ring with a small amount of food grade petroleum jelly. Seat O-ring back in groove. Note: Ensure that O-ring is properly seated in groove for a water-tight seal.
5. Place new cartridge in Canister with mesh top facing up. Replace Housing Cap. Tighten with minimal force using provided wrench if necessary. DO NOT OVERTIGHTEN.
6. Before use, turn on water source and flush filter for two minutes to remove any carbon fines.
7. Note date of first use on the label included with a permanent marker. Adhere label to canister.

