



875 SCARFFER™

Instructions

The scarf joint

The scarf joint is the optimum method of joining plywood panels for the builder who wishes to make the panels longer or wider than the standard plywood dimensions. A standard scarf joint has eight times more bonding area than a traditional butt joint with no increase in panel thickness. The scarf joint effectively transfers the full load of the plywood from one panel to another without the need for additional reinforcing.

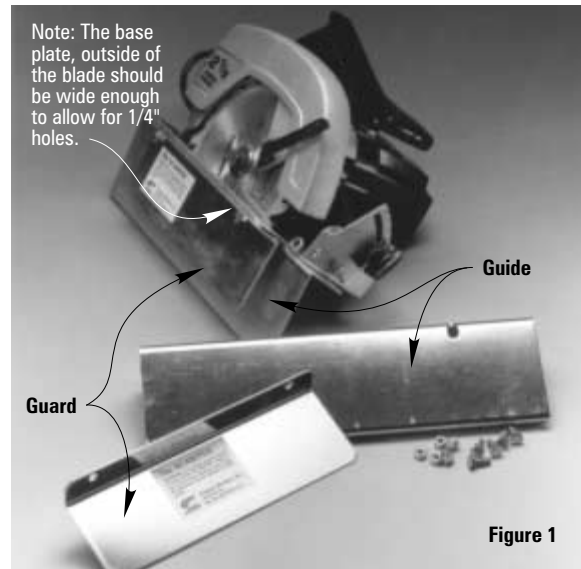

The Scarffer

The Scarffer is an attachment for a hand-held, power circular saw. When properly mounted, the Scarffer will make a precision, low-angle bevel cut in a plywood panel for scarf joints. There are two parts to your Scarffer: a guide and a safety blade guard. The guide is the larger part and has two flanges. Notice the pre-drilled mounting holes in the wide flange and the observation hole cut in the shoulder. The safety guard has a single narrow flange with two mounting holes.

CAUTION! Read and follow these instructions before you attempt to use the Scarffer. Safe and proper operation of this tool depends upon selecting a proper circular saw and blade, mounting the Scarffer correctly on the circular saw, and using the Scarffer in accordance with the instructions provided within this manual. Do not use the saw without the Scarffer guard in place.

Saw and blade requirements

Select a 7/4" circular saw with the base plate area on the outside of the blade, wide enough to accommodate a 1/4" hole (See Figure 1). Some "stamped" metal bases do not allow this and are not recommended without additional modification.

It is important to use a sharp, 7/4" carbide-tip saw blade when cutting scarfs. Although the plywood is thin, the blade is in effect making a 2" deep cut. In addition, the blade makes its cut at a very close angle to the glue joints in plywood, substantially increasing the abrasive wear on a blade. This would quickly dull a standard steel blade.

Mounting the Scarffer Guide

1. Unplug the saw before mounting the Scarffer.
2. Adjust the saw for its deepest cut and set the bevel angle to 7 1/2° (See Figure 2—FRONT VIEW). (This bevel angle produces an 8-to-1 ratio scarf.)
3. Clamp or brace the saw with the base plate facing up. Retract the safety guard and temporarily wedge it in the retracted position. (CAUTION! Remember to remove the wedges before operating the saw. If the Scarffer is removed at a later date, be certain the safety guard operates freely before using the saw.)
4. Position the Scarffer guide on the base plate to mark the proper location of the mounting holes. Place the wider flange of the guide on the base plate, with the center of the observation hole lined up front tip of the saw blade (See Figure 2). Position the guide 1/16" away from the front saw blade tip (at the observation hole). Position the guide 3/32" away from the rear saw blade tip (See Figure 2). The slightly increased clearance at the rear of the blade assures that the trailing edge of the blade will not damage the smooth cut made by the leading edge of the blade. Temporarily clamp the guide to the base when it is in the proper position.
5. Trace the location of the guide's three pre-drilled mounting holes onto the saw base plate. If a pre-drilled hole in the guide does not line up with a suitable location on the saw base, mark a new location on both the guide and the base plate at the nearest suitable location to the pre-drilled hole. The locations should allow clearance between the ends of the bolts and the saw motor. Remove the guide after marking the hole locations.

6. Drill 1/4" holes through the marked locations on the saw base plate and if necessary through the new locations on the guide. Be careful not to damage the saw housing when drilling through the base. Do not let drilling chips fall inside of motor.

7. Mount the guide to the saw base with the bolts provided. Pass the bolts up through the base and tighten the lock washers and nuts against the guide. Recheck the position of the guide. If necessary, elongate the holes with a round file to move the guide to the position described in Step 4.

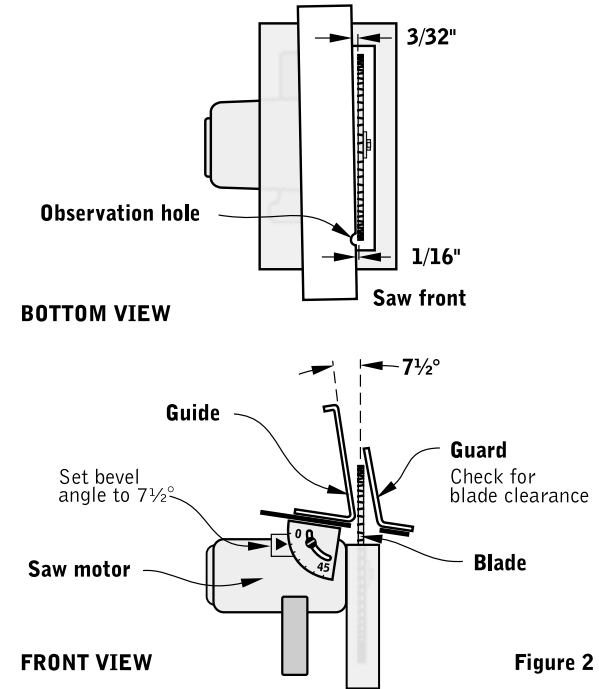

Mounting the Scarffer Guard

1. Position the Scarffer guard on the opposite side of the saw blade from the guide. Place the smaller flange of the guard on the saw base so the guard is parallel to the guide and far enough away to clear the tip of the blade by at least 1/8" (See Figure 2).
2. Trace the location of the guard's pre-drilled holes onto the saw base. If the pre-drilled holes do not line up with a suitable position on the saw base, mark new locations on both the guard and the base at the nearest suitable location.
3. Drill 1/4" holes through the marked locations on the saw base and if necessary through the new locations on the guard.

4. Mount the guard to the saw base plate with the bolts provided. Pass the bolts up through the base and tighten the lock washers and nuts against the guard. Recheck the position of the guard for blade clearance and elongate the holes if necessary to adjust to the proper position.

5. Remove any temporary wedges or blocks holding the saw safety guard and check to be sure blade moves freely, clear of the Scarffer guide or guard.

Blade angle settings and scarf angles

The standard blade angle setting recommended in Mounting the Scarffer Guide-Step 2 (7 1/2°), will cut a 2" wide bevel on a 1/4"-thick plywood panel or about an 8-to-1 ratio (7.5°) scarf angle. Increasing the saw's blade angle setting will result in a shallower scarf angle. An 8-to-1 ratio is adequate for plywood panels. Harder or denser materials require a higher ratio (shallower scarf angle and more bonding area).

The accuracy of the angle gauge may vary from saw to saw. While it is not critical that scarf joints precisely match a specific angle, it is critical that the two mating scarfs of the same joint are exactly the same scarf angle. Do not change the saw's blade angle between the two mating cuts of the same scarf joint.

Preparing the plywood

1. Lay the plywood panel on a bench or table that will fully support the panel and allow the scarf edge of the panel to lay flat. A full sheet of 3/4" plywood placed on a smaller table or saw horses will make a satisfactory cutting table.
2. Position edge of the panel to be cut so that it extends approximately 3 1/2" from the table edge, and parallel to the table edge (See Figure 3).

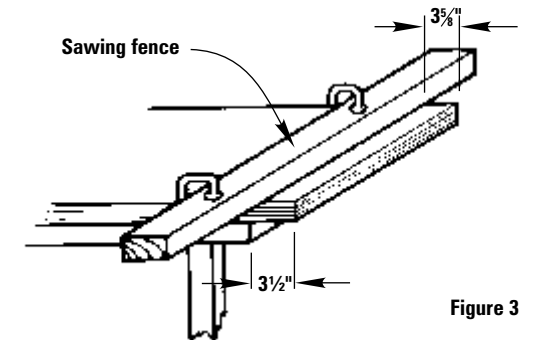

3. Select a straight piece of lumber at least a foot longer than your panel width to act as a sawing fence. The fence should be wide enough to resist bending in the center. A 4"-6" wide piece of 3/4" plywood is adequate for a 4' cut, a 12"-16" wide fence for 8' cuts. Place it

parallel to the proposed cut, $3\frac{5}{8}$ " from and parallel to the panel edge. Clamp the fence securely to the top of the panel with the clamps on the side of the fence away from the cut (See Figure 3). Narrower fences may require a temporary nail or screw in the center of the fence to prevent flexing during the sawing operation.

Making the scarf cut

1. Clear the saw travel area of obstructions. **WARNING!** Do not let anyone stand in front of the Scarffer while in use. Loose rippings from the plywood can be ejected at high speed from the front of the Scarffer. Always wear proper safety clothing and eye protection when operating the Scarffer.

2. Place the saw on the edge of the panel, motor side up with the small flange of the Scarffer guide against the fence. Hold the saw with the right hand, pressing the guide firmly against the fence. Place your left hand forward on the Scarffer guide at the beginning of the cut, pressing the guide firmly down against the panel (See Figure 4).

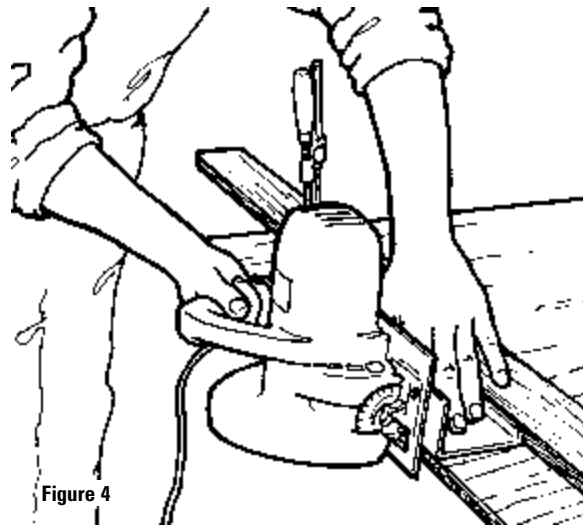

3. Depress the trigger and guide the saw slowly and smoothly into the wood, with the Scarffer riding flat on the plywood panel and tight against the fence. Do not allow the saw to tilt up, tip sideways or come up from the panel. Do not force the saw—take your time.

4. After the saw has progressed into the panel about a foot, gradually shift the left hand back to the middle of the guide, keeping the guide pressed against the panel. When the saw approaches the end of the cut, shift the left hand to the rear of the Scarffer and finish the cut. This keeps the Scarffer tight to the fence and flat on the panel. We recommend practicing on a piece of scrap plywood.

If you are having difficulty:

- ✓ Be sure the blade is sharp.
- ✓ Check the measurements between the Scarffer guide and the blade for proper alignment.
- ✓ Be sure the fence is properly positioned, clamped tightly, and stiff enough to resist flexing which might cause an uneven cut.
- ✓ Be sure the guide is held flat on the panel and tight to the fence. Lifting or tipping the saw will result in an uneven cut. Warped plywood or an uneven surface on your bench will also prevent a smooth, even cut. The fence itself can be used to flatten a warped panel, but may need nails or screws in the middle to hold the panel flat.

Scarf cuts on panels thicker than $\frac{1}{4}$ "

When cutting plywood thicker than $\frac{1}{4}$ ", the blade won't reach all the way through the wood. The scarf must be completed with a hand plane. Figure 5 illustrates the procedure for finishing a scarf on edge of a partially cut, thicker panel.

1. To complete the cut, flip the plywood over on the bench. Score the plywood with a straight edge and knife above deepest part of the cut. Break away the scrap. If the plywood is very thick, you may have to make a shallow saw cut instead (See Figure 5).

2. Locate and mark the back edge of the 8-to-1 bevel (where the blade would have come out if it were a larger diameter). Multiply the plywood thickness by 8 (if the blade angle was set at 0°). Then measure back from the edge that distance. For example, on $\frac{3}{8}$ " plywood the back edge of the cut is 3" from the panel edge ($8 \times \frac{3}{8} = 3$ "). On $\frac{1}{2}$ " ply, the back edge of the cut is 4" from the panel edge (See Figure 5).

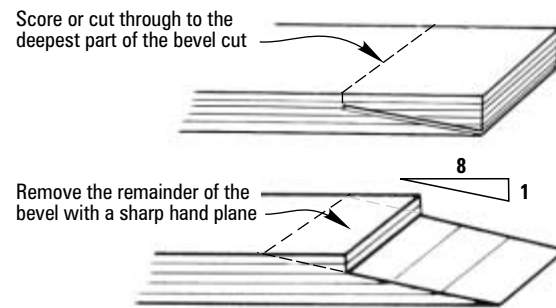

Figure 5

3. Position the panel on your bench so that the thin edge of scarf is fully supported. Using a sharp hand plane, remove the remainder of the wood between line marking the back edge of the bevel and the sawed

surface of the bevel. When completed, the scarf joint should be a consistent, flat, sloping surface. Check the uniform flatness of the surface with a metal straight edge.

Bonding the scarf joint

The greatest difficulty in bonding plywood panels together is finding a flat surface large enough to align both panels while they are being joined. The floor is often the best option.

1. Position the panels to check alignment. Cover the surface beneath the joint with plastic to prevent inadvertent bonding.

2. Wet out the scarf joint surfaces with unthickened epoxy to help prevent an epoxy-starved joint. You do not have to wait for this coat to cure before applying the bonding mixture.

3. Apply thickened epoxy to one side of scarf joint. Thicken the epoxy mixture to a catsup consistency with an adhesive filler such as 403 Microfibers or 406 Colloidal Silica.

4. Place the panels together and align the scarfed edges so they are perfectly aligned—neither over matching nor under matching bonding surfaces. When properly aligned, place a staple at each end of the joint to fix the position of the panels (See Figure 6).

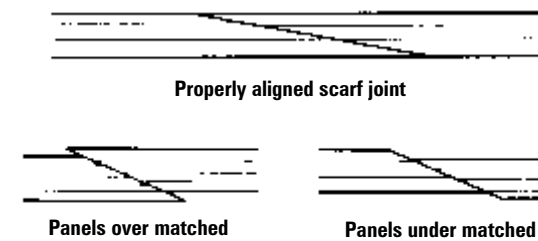

Figure 6

5. Clamp the joint with enough pressure that a small amount of thickened epoxy squeezes out uniformly along the joint. Avoid excessive clamping pressure. Check fairness with metal straight edge and adjust the clamping pressure to achieve a smooth, continuous surface between panels all along the joint. Staples are often sufficient to secure the joint until the mixture cures. Tacking strips, thin strips of wood, plywood or even mixing sticks, will distribute the load evenly across the length of the scarf. Staple through the strips into place, and into the table or floor. As you staple the strips into place, excess epoxy should squeeze out of the joint. Remove any excess epoxy before it cures.

6. After the cure is completed, remove all staples and lightly sand the scarf joint until it is smooth. Staple holes can be filled in a later operation.

Bonding scarf joints directly on the boat

Scarf-cut panels can also be joined in place directly on a boat hull. Plan carefully and cut panels are so that the center of the scarf joints are positioned over the center of frames. The first sheet is bonded to the frames with the sawed scarf facing out. The second panel is cut with the matching scarf facing in and the opposite end with the scarf facing out (See Figure 7). The second panel is bonded to the frames while aligning the scarf joint as previously described. Tacking strips and staples (or nails) are used to temporarily hold the scarf joint and the panel to the frames while the epoxy cures.

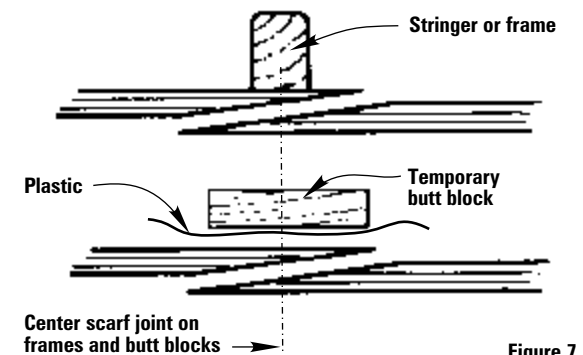

Figure 7

If the scarf joint does not land on a frame, you can still execute a strong scarf joint. Use a temporary butt block on the backside to receive the staples. Remember to put a layer of plastic under the butt block and tacking strips and prevent permanently gluing them to the plywood panels (See Figure 7).

For more information about scarfing read Chapter 12 in the 2005 edition of *The Gougeon Brothers on Boat Construction* or contact the West System technical staff.



West System Inc.
PO Box 665
Bay City, MI 48707 USA
866-937-8797
www.westsystem.com

WEST SYSTEM is a registered trademark of West System Inc.
© 2005 West System Inc.

R60-087 G0105