

Instruction Sheet for Tillotson Model AJ Carburetor

NOTE: Numbers in parenthesis used in these instructions are the index numbers on the exploded view drawing on opposite side of sheet.

I. DISASSEMBLY

Disassemble the carburetor to the extent indicated by the drawing on opposite side of sheet, and in the order of index numbers on the drawing. Removal of these parts will permit proper inspection and cleaning of the various carburetor parts. Give special attention to the following:

a. Check adjusting screws (3 and 6) for damage caused by over-tightening against their respective seats in the carburetor body (18). Replace damaged or defective parts.

b. Inspect the float assembly (17) for damage caused by improper handling and damage to the coil spring which is attached to the float. Replace damaged or defective parts.

c. Check the idle tube (8) to make certain the small metering hole at the lower tip is clean and free of foreign material.

CAUTION: Do not use a metal wire or drill to remove foreign material from idle jet or other metering parts. Use compressed air for cleaning.

d. After cleaning, check the body assembly (18) carefully to make certain that all passages are clear.

II. CLEANING

A regular commercial carburetor cleaning solvent is ideal for cleaning the carburetor body and parts. If this solvent is not available, procure some low-grade lacquer thinner and clean the parts as follows:

a. Use enough solvent to cover the body assembly (18) and drop all parts except float into the solvent.

b. Allow the body assembly (18) to soak for approximately 10 minutes to loosen all foreign material in internal passages.

c. Using a small bristle brush, brush the parts until all foreign accumulations have been removed.

d. Use clean solvent to rinse, then blow out all passages and orifices with compressed air.

CAUTION: Do not use rags or waste for cleaning or drying parts. Do not soak float assembly in cleaning solvent.

III. REASSEMBLY

Replace old parts with corresponding new parts in

kit and assemble carburetor in reverse order of index numbers on the exploded drawing on opposite side of sheet. Be sure to observe the following conditions:

a. After installing inlet needle and seat (15), gasket (16), float operating lever (14) and float lever pin (13), hold the float bowl cover (11) up-side down and rest a scale or straight edge on the lever parallel with the gasket surface (gasket off) of float bowl cover. (See figure 1.) The edge of scale should be $\frac{7}{16}$ inch above surface as shown. To adjust, bend levers carefully.

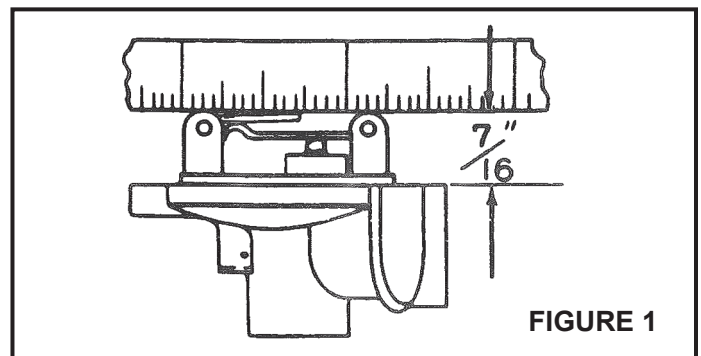

b. When installing main adjustment screw (3) and idle adjustment screw (6), use care not to force them against their seats by stopping as soon as contact with the seat is felt. Back the screws out (counterclockwise) for a trial setting as follows:

One turn for screw (6) and two turns for screw (3). These adjustments must be rechecked after starting the engine.

IV. ADJUSTMENT.

Install the carburetor on the engine, connect throttle and choke controls (and air cleaner, if used).

a. Start and warm up the engine.

b. Accelerate the engine by opening the throttle quickly and note response. Adjust the main adjustment screw (3) clockwise (toward lean) as far as possible to prevent engine from hesitating when throttle is opened quickly.

c. Adjust the idle adjustment screw (6) until the engine idles without stalling. The idle adjustment should be performed after the power adjustment.

NOTE: This carburetor has a fixed idle-speed adjustment by use of a skeleton type throttle valve which permits a predetermined amount of air to pass into the engine when valve is closed. No attempt should be made to alter this situation.

d. Sharpen all adjustments by adjusting the idle and main adjustment screws a little at a time until the engine operates efficiently both under load and at idle. A short period of time will be required after making an adjustment to permit the carburetor and engine to “settle down”.

Therefore, a few seconds should be allowed between each trial adjustment.

e. After operating the equipment for a few minutes check accuracy of both adjustments by rotating the screws very slightly and noting engine response.

Parts List for Tillotson Model AJ Carburetor

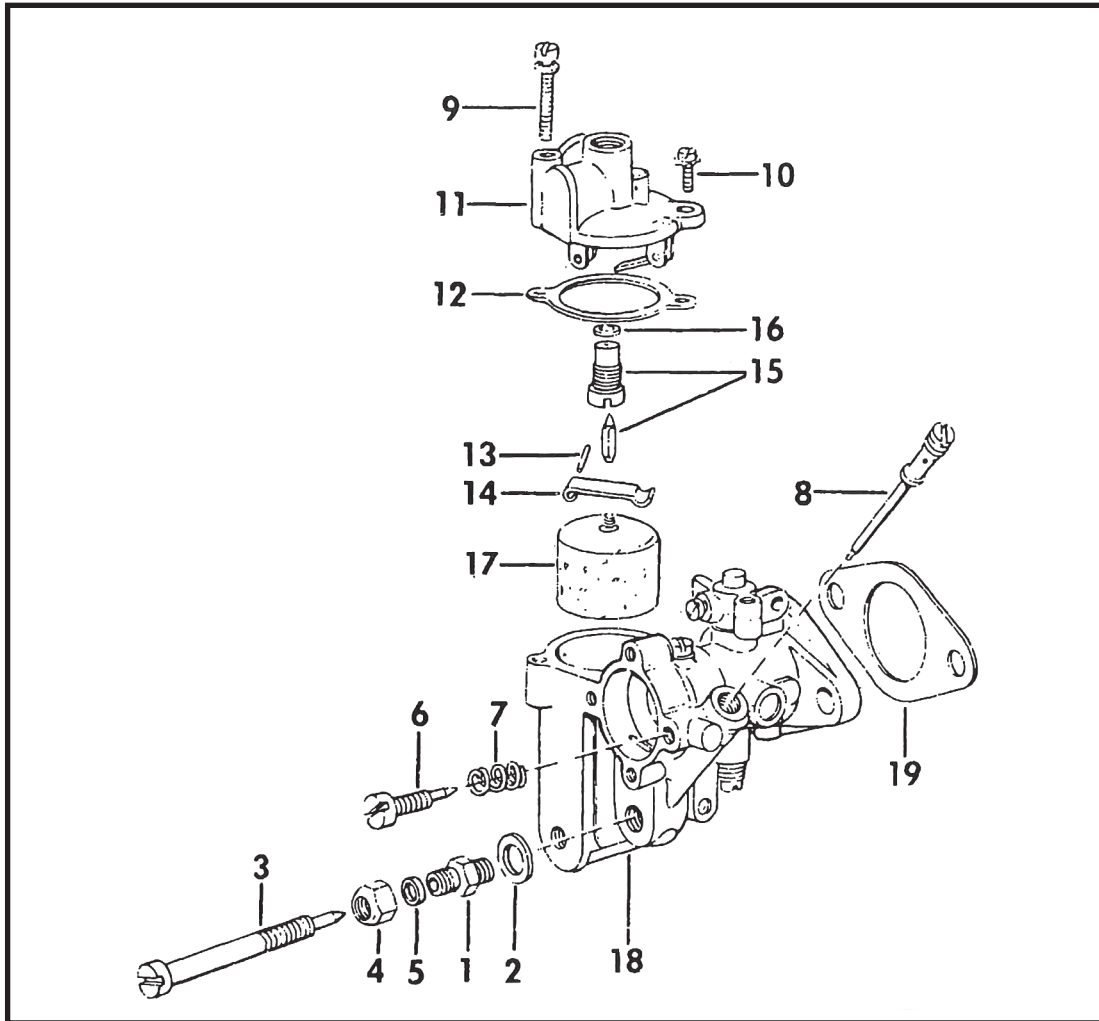

- | | |
|---|--------------------------------|
| 1. Main adjustment screw gland | 11. Float bowl cover |
| 2. Main adjustment screw gland gasket | 12. Float bowl cover gasket |
| 3. Main adjustment screw | 13. Float lever pin |
| 4. Main adjustment screw packing nut | 14. Float operating lever |
| 5. Main adjustment screw packing | 15. Inlet needle and seat |
| 6. Idle adjustment screw | 16. Inlet needle seat gasket |
| 7. Idle adjustment screw spring | 17. Float assembly |
| 8. Idle tube | 18. Body assembly |
| 9. Float bowl cover screw and lockwasher (long) | 19. Carburetor mounting gasket |
| 10. Float bowl cover screw and lockwasher (short) | |