

Assembly

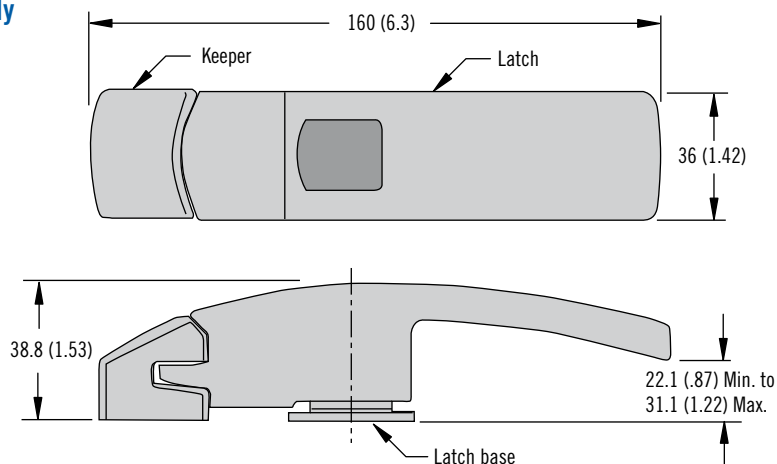

Panel Preparation

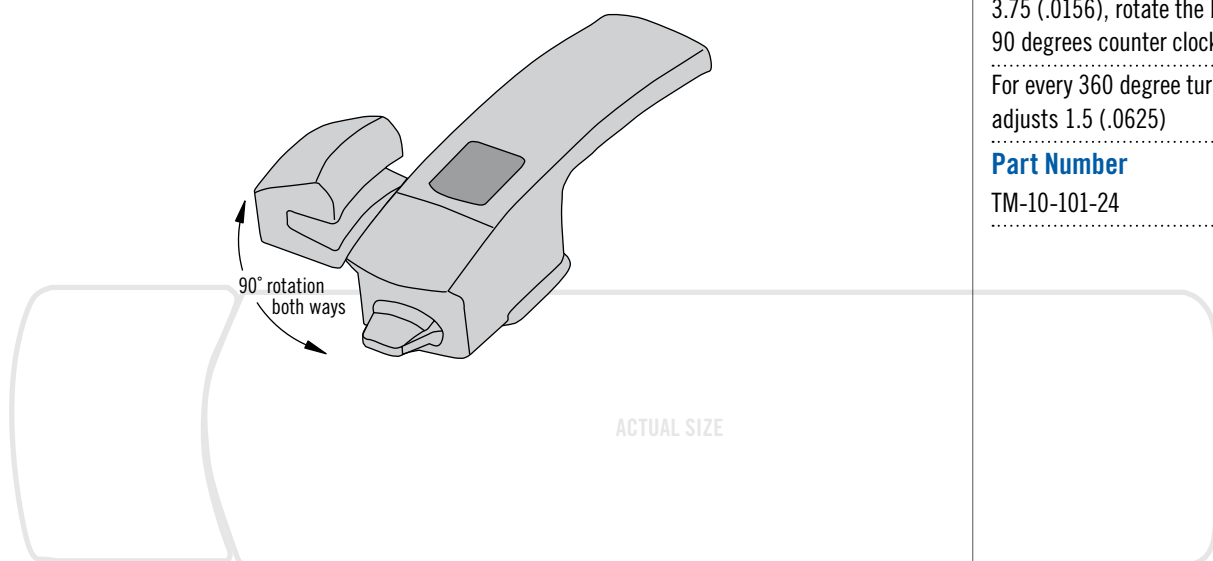
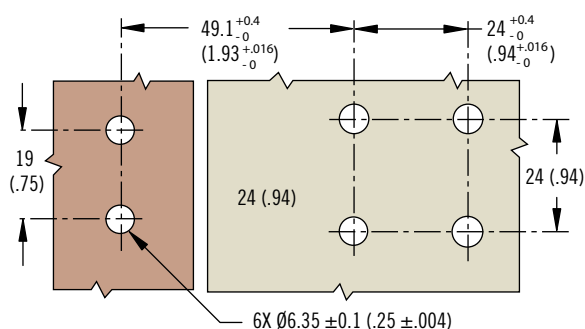

- Stylish latch for transom and swim platform doors
- Intuitive operation with push button and turn handle actuation
- Premium finish and corrosion resistance

Material and Finish:

Handle, Keeper, Base button and Sleeve: 316 grade stainless steel electropolished

Keeper insert: Nylon black

O-ring: EPDM natural

Screw, Spring and Nut: 304 Stainless steel passivated

Installation Notes

Fine tuning latch and keeper alignment:

To increase the height of the latch by 3.75mm (.0156 inch), rotate the base of latch 90 degrees clockwise

To decrease the height of the latch by 3.75 (.0156), rotate the base of latch 90 degrees counter clockwise

For every 360 degree turn, the height adjusts 1.5 (.0625)

Part Number

TM-10-101-24

